

Encoder Installation Manual

NorthStar™ brand

SERIES HSD44

Extreme Heavy Duty Encoder

Document No.: 702749-0001
Revision Level: E
January 15, 2019



SPECIFICATIONS

STANDARD OPERATING CHARACTERISTICS

Code: Incremental, Optical
Resolution: 1024 & 2048 PPR (pulses/revolution),
Format: Two channel quadrature (AB) with Index (Z), and complementary outputs
Phase Sense: A leads B for CCW shaft rotation viewing the shaft clamp end of the encoder
Quadrature Phasing: 90° ± 15° electrical
Index: 150° to 300° A leads B, CCW (From Clamp End)
Symmetry: 180° ± 18° electrical
Waveforms: Squarewave with rise and fall times less than 1 microsecond into a load capacitance of 1000 pf

ELECTRICAL

Input Power: 5-30VDC. 80 mA max., not including output loads.
Outputs: 7272 Differential Line Driver: 40 mA, sink or source
Frequency Response: 125 kHz (data & index)
Noise Immunity: Tested to EN61326-1
Electrical Immunity: Reverse polarity and short circuit protected
Termination: 18" pigtail or 18" pigtail with MS Connector. See Ordering Information
Mating Connector:
10 pin MS, style MS3106A-18-1S (MCN-N6)
10 Pin, NEMA4 Style (MCN-N6N4)

MECHANICAL

Mechanical Interface: Electrically isolated stainless steel shaft flex coupling
Coupling: 16mm, flexible
Mating Shaft Length: 0.47" to 0.625" (11.9mm to 15.9mm)
Shaft Speed: 6000 RPM, max.
Bearings: 6107
Housing Material: Aluminum Alloy
Disc Material: PET
Weight: 4 lbs.

ENVIRONMENTAL

Operating Temperature: -30 to 100°C
Storage temperature: -40 to 100°C
Shock: 400g, 6mSec
Vibration: 5-3000 Hz, 20g
Humidity: Up to 98% (non-condensing)
Enclosure Rating: NEMA 6 / IP67

ELECTRICAL CONNECTIONS

Function	Pin	Wire Color
Sig. A	A	BRN
Sig. B	B	ORG
Sig. Z	C	YEL
Power +V	D	RED
Com.	F	BLK
Case	G	GRN
N/C	E	—
Sig. \bar{A}	H	BRN/WHT
Sig. \bar{B}	I	ORG/WHT
Sig. \bar{Z}	J	YEL/WHT

DATA AND INDEX

Not all complements shown
A shown for reference

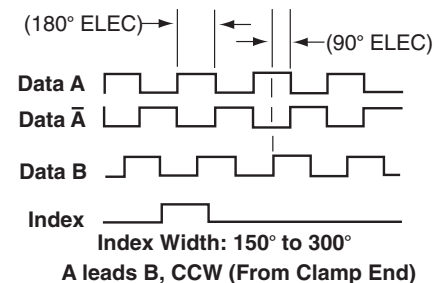

IMPORTANT INSTALLATION INFORMATION

GENERAL GUIDELINES

Encoders provide quality measurements and long life when common sense, care, and accurate alignments are provided during installation. The following general guide-lines will help to ensure a trouble-free installation.

Mounting the Encoder

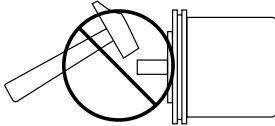

Do not shock the encoder.

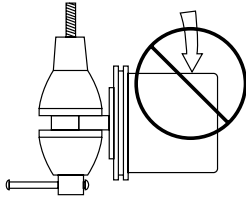

Do not subject the encoder to axial or radial shaft stresses.

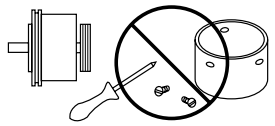

Do not disassemble the encoder.

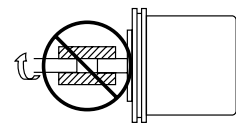

Do not use a rigid coupling.

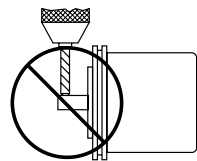

Do not tool the encoder or its shaft.

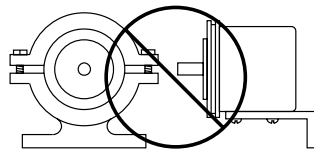

Do not use makeshift techniques to mount the encoder.

Wiring the Encoder

- Never connect or disconnect the encoder connector or wiring while power is ON. Doing so may damage the encoder.
- Power should always be connected to the + side of DC power.
- Common should always be connected to the - side of DC power.
- Never connect A, B, or Z to the + or - side of DC power.

ELECTRICAL CONNECTIONS

Cable - The use of shielded cable is recommended for all encoder installations. When a Dynapar brand encoder is ordered, the type of termination is generally defined (usually the last selectable code in Ordering Information). If a code for a cable was indicated, the encoder was manufactured to include a shielded cable. If any other type of termination was selected or if selection of termination type was not requested, a cable assembly must be ordered. (The cable assembly easily hooks onto the encoder's connector making it ready for wiring).

To determine which cable assembly to order, refer to the Electrical Connections table (in the encoder's manual).

ELECTRICAL CONNECTIONS (cont.)

In some cases, there may be more than one table or the table may be broken into sections due to different output types. If so, refer to the information listed for the output type selected for the encoder (in Ordering Information).

Wiring should be run through dedicated conduits or harnesses (not shared with any other wiring) which are spaced at least 12 inches apart. This protects the cable from physical damage while providing a degree of electrical isolation. Also, do not run cable in close proximity to other conductors which carry current to heavy loads such as motors, motor starters, contactors, or solenoids. Doing so could result in electrical transients in the encoder cable which cause undesired signal pulses.

NOTE: Never connect or disconnect the encoder connector or wiring while power is ON. Doing so may damage the encoder.

Grounding: For applications with high ground potential differences, DO NOT ground the encoder through both machine and controls end. Connect the shield at the controls end only. **NOTE: If the shield is connected at both ends, grounding problems that degrade system performance can result.**

CE Grounding Measures – For best EMC immunity the cable screen must be grounded on both encoder and controls end. For cable lengths longer than 30m or outdoor applications, additional measures must be implemented to comply with CE requirements. Connection of the encoder to DC power supply network is prohibited if CE compliance is required. CE-compliant products are tested to EN61326-1 EMC.

In all cases, system CE compliance is ultimately the responsibility of the manufacturer integrating the encoder.

FEATURES

All encoders have the following electrical features:

- Power (+DC)
- Common
- Output Signal(s)

Power (also referred to as supply, power source, and power +V/VCC) is always +DC for encoders. **Therefore, power should always be connected to the positive (+) side of DC power.** In addition, encoder power should be regulated to within $\pm 5\%$ at the encoder and should be free of induced transients. Common (also referred to as Com, supply common, and ground) is generally a black wire (verify via Electrical Connections table).

IMPORTANT INSTALLATION INFORMATION

FEATURES (cont.)

Common should always be connected to the negative (-) side of DC power.

All encoders have at least one output signal (A); however, it is common for encoders to have three signals A, B, Z (may also be referred to as C, X, or index). The outputs should each be connected to the receiving device at the appropriate terminal. NOTE: Never connect A, B, or Z to the + or - side of DC power.

When encoders have a differential line driver, there are two signals for each of the outputs. Each signal (A, B and Z) has a compliment or inverse (A⁻, B⁻ and Z⁻ referred to as A not, B not, and Z not). The signal and its compliment (i.e. A and A⁻) are separate outputs. Connect each output to a separate input.

NOTE: Never connect these signals together or to the + or - side of DC power. Never connect differential signals to the same input.

CONNECTIONS

Obviously not all receiving devices are the same. However, connecting your encoder to one, no matter what type or brand it may be, is not difficult. As discussed in the previous section, all encoders have certain electrical features. Each of these features/functions are identified in the encoder's Electrical Connections table along with its corresponding pin and wire color. Each wire specified in the table must be connected to the receiving device.

Determining where to connect each wire is as easy as following the Electrical Connections table and matching each wire to the proper terminal on the receiving device. In general, no matter what type of receiving device you are using, the terminal strip is marked, indicating the proper location for each function/wire. These markings may either be numbers or text labels identifying functions. If they are numbers, the receiving device's manual should define what function corresponds to each number.

Since receiving devices are made by various manufacturers, not all text labels/references are the same. There are various ways to identify each function. Following are a few examples:

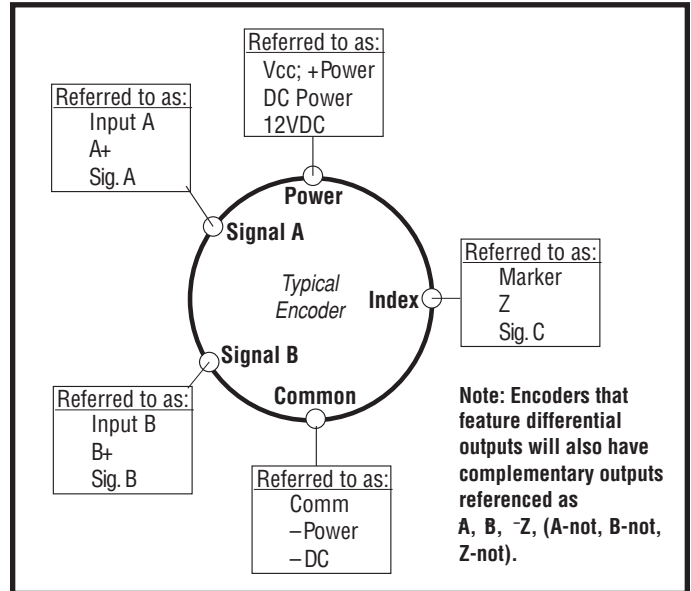

FREQUENTLY ASKED QUESTIONS

There are additional colored wires which are not referred to in the Electrical Specifications table. What do I do with them?

Do not connect them to the receiving device. Any unused encoder signal wires must be individually insulated and tied back. They should NEVER be in contact with common, power sources, or other output signal lines.

The encoder is correctly connected to the receiving device per the Electrical Specifications table and the receiving device's terminal strip label; however, it's counting in the wrong direction. What's wrong?

In order to reverse the counting direction, the output signal connections must be switched. If the encoder has a single ended output, swap A and B. If the encoder has a differential line driver, swap A and A⁻.

I've connected the encoder and it doesn't work (No Outputs). What can I do?

Many encoders have internal protection circuits which shut down the encoder to prevent damage if the input power is not correct or the outputs are overloaded. Check the following: Input Voltage (is it too high?); Input Polarity (is it reversed?); and Output Wiring (are they wired properly?).

I've read and followed the technical manual and these guidelines and the encoder still doesn't work properly. Help!?

Calm down - help is at your fingertips! Simply pick up the phone and dial our Applications Engineering Department at 1-800-234-8731 (US & Canada) or 847-662-2666 from 8:00 AM to 4:45 PM (Central time) Monday - Friday. One of our engineers will gladly help you solve the problem.

MECHANICAL INSTALLATION

A. GENERAL OVERVIEW

The NorthStar Series HSD44 is a harsh-duty speed and position transducer that when mounted to a rotating shaft, produces output pulses that are directly proportional to the shaft speed and direction. The encoder is attached to the motor shaft via a stainless steel flexible coupling that compensates for motor shaft end-play and run-out. The clamp is also electrically isolated from the encoder to ensure motor shaft currents do not ground through the encoder bearings. Due to this specialized coupling, special precautions must be taken during installation as outlined in this manual.

B. SHAFT EXTENSION

Solid shaft preferred, keyway allowed (key must be removed); flatted shaft must not be used. The shaft extension length range is .47" to .625". Installations that use a press-fit or screwed-on stub shaft adapter should align the stub shaft to 0.002" TIR or less using a dial indicator.

C. REQUIRED TOOLS & MATERIALS

Tool	Purpose
Caliper & Dial Indicator Gages	Shaft Checks
1/4" Hex Key Wrench	Shaft Clamp Access Plug
9/64" Ball End Hex Key Wrench	Shaft Collar Clamp
5/32" Ball End Hex Key Wrench	Shaft Clamp Alignment Screw
3/16" Hex Key Wrench	Encoder Mounting Screws
10mm Hex Key Wrench	Stopping Plug
Open End Adjustable Wrench	Cable Gland
7/64" Hex Key Wrench	Terminal Box Cover
1/8" Flat Blade Screwdriver	Terminal Block Wiring
Torque Wrench, 20-75 inch pound range	Tightening Fasteners

CAUTION: Upon initial inspection of the shaft coupling area of the HSD44 you will notice a 10-32 screw that extends through the encoder body and into the shaft coupling.

DO NOT remove this Coupling Locating Screw until directed to do so in Step 9 of the Installation Procedure.

Please familiarize yourself with the following as seen in the magnified view drawing below:

1. Shaft Clamp Screw
2. Shaft Clamp Access Plug
3. Flex Coupling Locating Screw
4. Coupling Locating Hole

Note: The encoder can be mounted on shafts of varying lengths (MIN 0.47 in, MAX 0.83 in).

ESD44 MOTOR MOUNT REQUIREMENTS

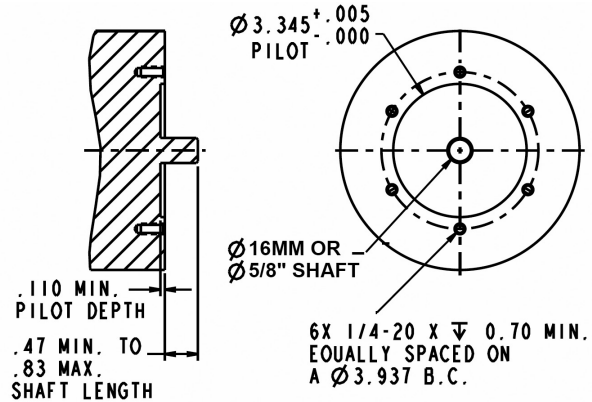

HSD44 COUPLING/CLAMP INSTALLATION

Note: Please refer to this figure when performing Installation Steps 7 – 11.

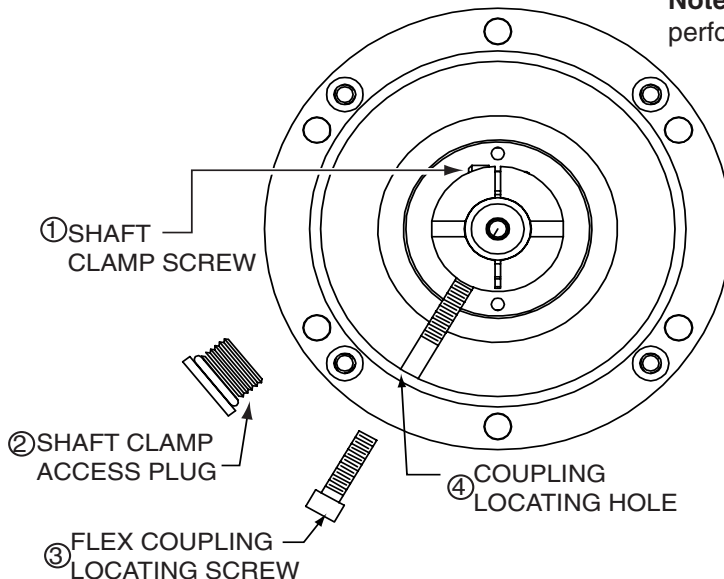

MECHANICAL INSTALLATION

STEP 1: Please reference the below diagram titled “EN 44 Motor Mount Requirements” to ensure that a correct mounting interface is provided for the mechanical installation of this encoder. The HSD44 has a 0.110 inch piloted face that is concentric with the Flex Coupling. Be sure to create a concentric pilot with the six 1/4-20 inch threaded holes on customer equipment as shown in the diagram.

STEP 2: Ensure the mounting interface and shaft extension are free of dirt, grease, or any other foreign matter. Check the shaft Total Indicated Run-out (TIR), and ensure that it does not exceed 0.005” TIR.

STEP 3: Using the 1/4” hex key, remove the Shaft Clamp Access Plug from the side of the encoder body.

STEP 4: Place the 9/64” ball end hex key into the access hole and loosen the Shaft Collar Clamp Screw. Place a small amount of threadlocker on the screw threads and re-install it into the Clamp Collar. Re-thread the screw into the clamp loosely. **DO NOT TIGHTEN.** Remove the 9/64” ball end hex key from the access hole.

STEP 5: Place a Lockwasher onto each 1/4-20 x 1” Encoder Mounting Screw (6 required). Apply a small amount of threadlocker to the screw threads.

STEP 6: While observing the proper orientation of the cable exit, slide the encoder straight over the motor shaft extension, and engage the encoder’s Flex Coupling. Note again, shaft engagement is MIN 0.47” MAX 0.83”.

Note: Please refer to ‘HSD44 Coupling/Clamp Installation’ figure (previous page) when performing Installation Steps 7 – 11.

STEP 7: Install the six Encoder Mounting Screws using the 3/16” hex key and torque to 75 inch pounds.

STEP 8: Using the 9/64” hex key, tighten the Shaft Clamp Screw. Torque to 45 inch pounds. Remove the 9/64” hex key.

CAUTION: The motor shaft must NOT be rotated until Step 9 (below) is performed, or damage to the encoder flex coupling will result.

STEP 9 Using the 5/32 hex key, completely remove the 10-32 x 1.5” Flex Coupling Location Screw. This screw is no longer needed for installation, instead replace with the shorter 10-32 x 7/8” screw. Obtain the 10-32 x 7/8” SHCS from the hardware kit (this screw has an o-ring under the head). Apply a small amount of threadlocker to the screw threads. Using the 5/32” hex key install the screw into the Coupling Locating Hole and torque to 20 inch pounds. The purpose of this shorter screw is to block the hole while in operation.

STEP 10 Apply a small amount of threadlocker to 1/8” NPT Shaft Clamp Access Plug threads. Using the 1/4 hex key, install the plug and torque to 60 inch pounds.

ORDERING INFORMATION

Ordering Information

To order, complete the model number with code numbers from the table below:

Code 1: Model	Code 2: PPR	Code 3: Bore	Code 4: Output Format	Code 5: Termination	Code 6: Options	Code 7: Special Option
HSD44	<input type="checkbox"/> <input type="checkbox"/> <input type="checkbox"/> <input type="checkbox"/>	<input type="checkbox"/>	<input type="checkbox"/>	<input type="checkbox"/>	<input type="checkbox"/>	<input type="checkbox"/> <input type="checkbox"/>
Ordering Information						
HSD44 Heavy Duty Hub Shaft Encoder	1024 2048	A 16mm	3 Differential ABZ, 5-30 in, 5-30 out (7272)	A 18" Cable K 1.5 ft (18") cable w/ in line 10 pin connector	0 No Options 1 Slotted Tether 2 Single Point 4.5" C-face Tether 3 Single Point 8.5" C-face Tether	Blank None 01 Extended Pilot (.156")

Accessories

Part Number	Description
HSD44ADAPTER45	4-1/2" NEMA Motor Adapter Plate

DIMENSIONS (in. [mm])

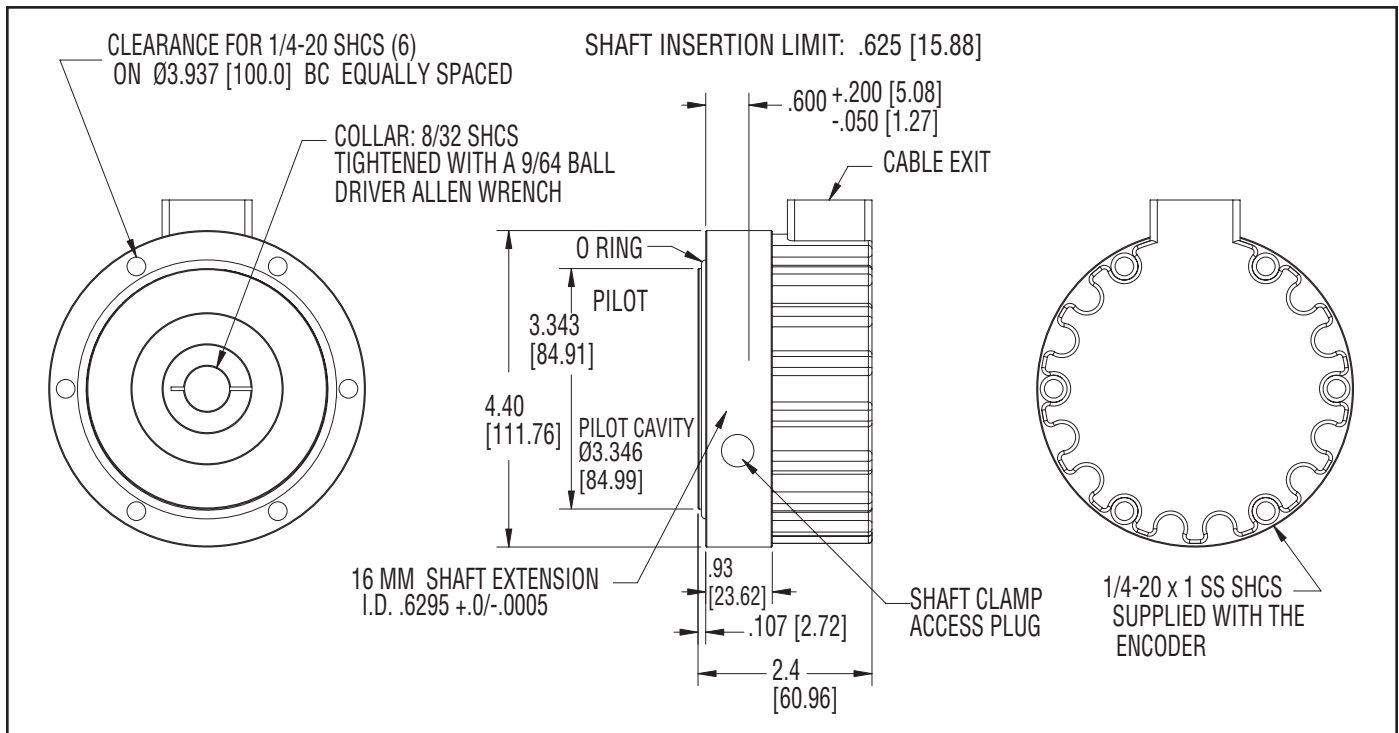

NorthStar™ brand is a trademark of DYNAPAR. All rights reserved.
Specifications subject to change without notice.
702749-0001 Rev. E ©2019 DYNAPAR