



Headquarters: 1675 Delany Road • Gurnee, IL 60031-1282 • USA
 Visit us at www.dynapar.com

Customer Service:
 Tel.: +1.800.873.8731
 Fax: +1.847.662.4150
custserv@dynapar.com

Technical Support
 Tel.: +1.800.234.8731
 Fax: +1.847.782.5277
dynapar.techsupport@dynapar.com

European Sales Representative
 Hengstler GmbH
 Uhlandstrasse 49, 78554 Aldingen
 Germany
www.hengstler.com

Encoder Installation Manual

NorthStar™ brand

NexGen RIM Tach 6200 SERIES

MILL-DUTY ENCODER

Document No.: 702952-0001
 Revision Level: H
 October 2, 2020

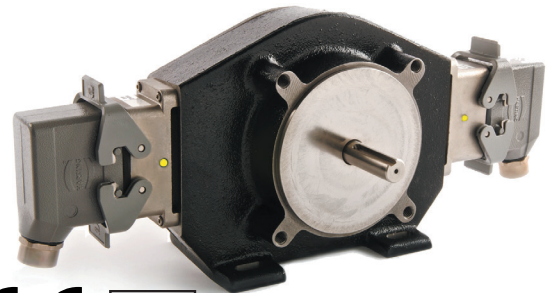

SPECIFICATIONS

STANDARD OPERATING CHARACTERISTICS

Code: Incremental, Magnetic
Pulses per Revolution: 60 to 4096 PPR
Phasing Sense: A leads B for Counter-Clockwise rotation (CCW) viewing the 4.5" C-face end of the Encoder
Quadrature Phasing: 90° ± 45°
Symmetry: 50% ± 15%
Number of Output Modules: Single or Dual

ELECTRICAL

Input Voltage Requirement: 5-26 Volts DC
Current Requirement: 95 mA typical per sensor module plus line driver load
Output Signals: IC-WE Differential Line Driver: 150mA, sink or source
Frequency Response: 0 - 180kHz Data & Index
Noise Immunity: Tested to EN61326-1
Electrical Immunity: Reverse polarity and short circuit protected
Connector: 10 pin industrial duty latching, sealed NEMA 4 & 12, IP65

MECHANICAL

Shaft Size: 0.625" (16mm) diameter with standard key, single or double ended
Shaft Speed: 7,000 RPM
Shaft Axial/Radial Loading:
High Strength Steel: 50 lb axial, 50 lb radial
Stainless Steel: 35 lb axial, 35 lb radial
Mounting Configuration: 4.5" [115mm] diameter, 56 C-Face Mount or accessory flange to meet NEMA MG1-4 standards; foot mount with 4 slotted bolt holes
Acceleration Rate: 3600 rpm/sec max
Housing Material: Cast Iron/Stainless Steel
Shaft Material Options: High Strength Carbon Steel or Stainless Steel
Weight: 27.6 lbs

ENVIRONMENTAL

Operating Temperature Range: -40°C to +100°C
Storage Temperature Range: -40°C to +120°C
Shock (Sensor Module): 30 G's Min
Vibration: 18 G's @ 5-2000 Hz spectrum
Humidity: Up to 98% (non-condensing)

ELECTRICAL CONNECTIONS

Signal	Connector Pin	Pigtail Cable	MS3102E18-1P
Common	1	Black	A
B	2	Green	E
A	3	Blue	D
Z*	4	Violet	C
No Connection	5	—	—
Vcc	6	Red	B
\bar{B}	7	Yellow	H
\bar{A}	8	Gray	G
\bar{Z} *	9	Orange	I
Shield	10	Braid	J

* Index (Z) optional. See Ordering Information

IMPORTANT INSTALLATION INFORMATION

GENERAL GUIDELINES

Encoders provide quality measurements and long life when common sense, care, and accurate alignments are provided during installation. The following general guide-lines will help to ensure a trouble-free installation.

Mounting the Encoder

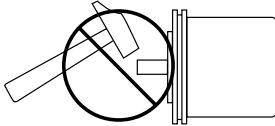

Do not shock the encoder.

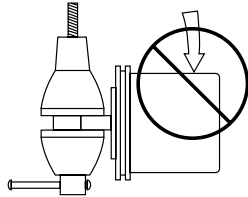

Do not subject the encoder to axial or radial shaft stresses.

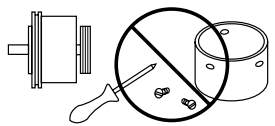

Do not disassemble the encoder.

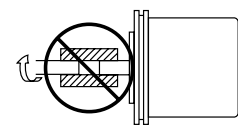

Do not use a rigid coupling.

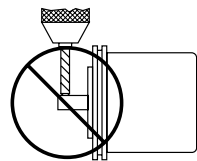

Do not tool the encoder or its shaft.

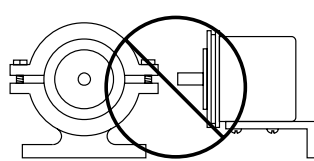

Do not use makeshift techniques to mount the encoder.

Wiring the Encoder

- Never connect or disconnect the encoder connector or wiring while power is ON. Doing so may damage the encoder.
- Power should always be connected to the + side of DC power.
- Common should always be connected to the - side of DC power.
- Never connect A, B, or Z to the + or - side of DC power.

ELECTRICAL CONNECTIONS

Cable - The use of shielded cable is recommended for all encoder installations. When a Dynapar brand encoder is ordered, the type of termination is generally defined (usually the last selectable code in Ordering Information). If a code for a cable was indicated, the encoder was manufactured to include a shielded cable. If any other type of termination was selected or if selection of termination type was not requested, a cable assembly must be ordered. (The cable assembly easily hooks onto the encoder's connector making it ready for wiring).

To determine which cable assembly to order, refer to the Electrical Connections table (in the encoder's manual).

ELECTRICAL CONNECTIONS (cont.)

In some cases, there may be more than one table or the table may be broken into sections due to different output types. If so, refer to the information listed for the output type selected for the encoder (in Ordering Information).

Wiring should be run through dedicated conduits or harnesses (not shared with any other wiring) which are spaced at least 12 inches apart. This protects the cable from physical damage while providing a degree of electrical isolation. Also, do not run cable in close proximity to other conductors which carry current to heavy loads such as motors, motor starters, contactors, or solenoids. Doing so could result in electrical transients in the encoder cable which cause undesired signal pulses.

NOTE: Never connect or disconnect the encoder connector or wiring while power is ON. Doing so may damage the encoder.

Grounding - DO NOT ground the encoder through both the machine and the cable wiring. Connect the shield at the input device only. **NOTE: If the shield is connected at both ends, grounding problems that degrade system performance may result.**

For European-based applications requiring CE compliance, cable length must not exceed 30m. Connect the shield to building ground on either the Encoder or Controls end. CE compliant products are tested to EN61326 EMC.

FEATURES

All encoders have the following electrical features:

- Power (+DC)
- Common
- Output Signal(s)

Power (also referred to as supply, power source, and power +V/VCC) is always +DC for encoders. **Therefore, power should always be connected to the positive (+) side of DC power.** In addition, encoder power should be regulated to within $\pm 5\%$ at the encoder and should be free of induced transients. Common (also referred to as Com, supply common, and ground) is generally a black wire (verify via Electrical Connections table). Common should always be connected to the negative (-) side of DC power.

All encoders have at least one output signal (A); however, it is common for encoders to have three signals A, B, Z (may also be referred to as C, X, or index). The outputs should each be connected to the receiving device at the appropriate terminal. **NOTE: Never connect A, B, or Z to the + or - side of DC power.**

IMPORTANT INSTALLATION INFORMATION

FEATURES (cont.)

When encoders have a differential line driver, there are two signals for each of the outputs. Each signal (A, B and Z) has a compliment or inverse (\bar{A} , \bar{B} and \bar{Z} referred to as A not, B not, and Z not). The signal and its compliment (i.e. A and \bar{A}) are separate outputs. Connect each output to a separate input.

NOTE: Never connect these signals together or to the + or - side of DC power. Never connect differential signals to the same input.

CONNECTIONS

Obviously not all receiving devices are the same. However, connecting your encoder to one, no matter what type or brand it may be, is not difficult. As discussed in the previous section, all encoders have certain electrical features. Each of these features/functions are identified in the encoder's Electrical Connections table along with its corresponding pin and wire color. Each wire specified in the table must be connected to the receiving device.

Determining where to connect each wire is as easy as following the Electrical Connections table and matching each wire to the proper terminal on the receiving device. In general, no matter what type of receiving device you are using, the terminal strip is marked, indicating the proper location for each function/wire. These markings may either be numbers or text labels identifying functions. If they are numbers, the receiving device's manual should define what function corresponds to each number.

Since receiving devices are made by various manufacturers, not all text labels/references are the same. There are various ways to identify each function. Following are a few examples:

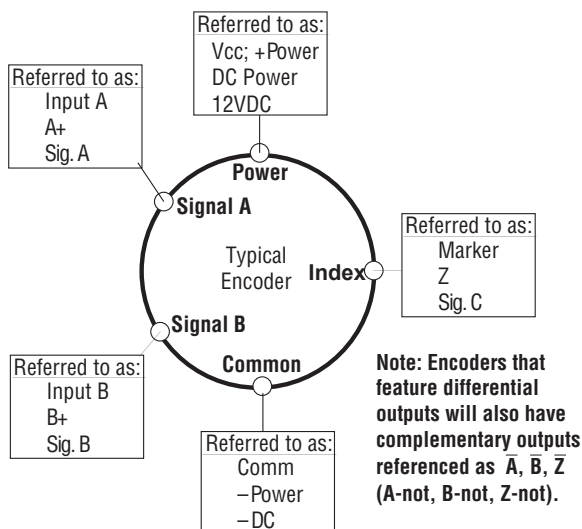

LED STATUS LIGHT:

A multicolor LED Status light will indicate to the user the overall condition of the encoder. The LED is built into the encoder and does not require any additional wiring or power to activate it. There are 4 basic status conditions for the light:

- 1) LED off:** No power to Encoder, Low supply voltage (<3.0VDC), Total Failure of Encoder
- 2) LED Green:** Correct Power to Encoder, Ready to operate, No wheel movement Detected
- 3) LED Flashing:** Unit operating, Unit sending pulses out
- 4) LED Flashing Red:** Low power to encoder (<4.5VDC), Line Driver Failure, Line Driver Over-Temperature (generally caused by external short circuit), Line Driver Logic Failure

FREQUENTLY ASKED QUESTIONS

There are additional colored wires which are not referred to in the Electrical Specifications table. What do I do with them?

Do not connect them to the receiving device. Any unused encoder signal wires must be individually insulated and tied back. They should NEVER be in contact with common, power sources, or other output signal lines.

The encoder is correctly connected to the receiving device per the Electrical Specifications table and the receiving device's terminal strip label; however, it's counting in the wrong direction. What's wrong?

In order to reverse the counting direction, the output signal connections must be switched. If the encoder has a single ended output, swap A and B. If the encoder has a differential line driver, swap A and \bar{A} .

I've connected the encoder and it doesn't work (No Outputs). What can I do?

Many encoders have internal protection circuits which shut down the encoder to prevent damage if the input power is not correct or the outputs are overloaded. Check the following: Input Voltage (is it too high?); Input Polarity (is it reversed?); and Output Wiring (are they wired properly?).

I've read and followed the technical manual and these guidelines and the encoder still doesn't work properly. Help!?

Calm down - help is at your fingertips! Simply pick up the phone and dial our Applications Engineering Department at 1-800-234-8731 (US & Canada) or 847-662-2666 from 8:00 AM to 4:45 PM (Central time) Monday - Friday. One of our engineers will gladly help you solve the problem.

MECHANICAL INSTALLATION

1.0 Description

The NextGen RT 6200 is a high performance and reliable Digital Tachometer, designed to provide position and velocity feedback from both AC and DC electric motors with pulse counts ranging from 60 through 4096 pulses per revolution. The RT 6200 utilizes rugged ductile iron casting construction and provides interchangeable sensor modules and magnetic technology capable of withstanding the harshest industrial environments. This ensures precise and consistent digital motor speed feedback.

The encoder is mounted in a variety of ways and utilizes, heavy-duty, one piece, Hall Effect sensor module with encapsulated surface mount electronics. The encapsulation provides resistance to water, oil mist, dirt, high temperatures, and other harsh environments. The sensor module includes a 10-pin quick connector requiring only a screwdriver for final electrical installation. The non-contact magnetic sensor and rugged magnetized pulse wheel are designed and machined to function properly without any adjustments. The RT 6200 provides precise, reliable speed signals for many monitoring and control applications, and is a standard feedback device for AC and DC variable speed drives. The unit is bi-directional providing square wave outputs.

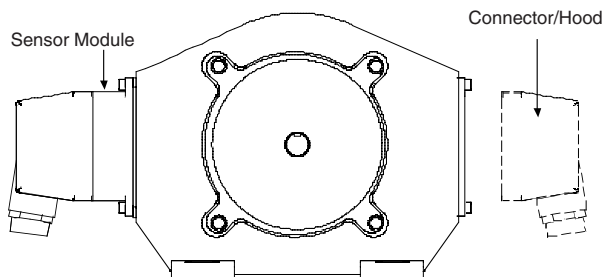

2.0 Preparation

The RT 6200 utilizes a modular construction that permits the user to configure the unit as a one or two signal output tachometer. Sensor modules are universal and interchangeable. If one output requires replacement, simply remove four screws, and replace with a new sensor module. No electrical adjustment or alignment is required. After unpacking the unit and verifying receipt of the items listed in the packing list, you may proceed with mechanical installation.

The encoder has no user maintainable components. The bearings are permanently lubricated and sealed for the operational life of the unit. The Pulse Wheel also needs no service. Disassembly of the unit will void the Warranty. The magnetic sensor and electronics modules need no adjustment, but can be replaced by the user in case of failure.

2.1 Painting Considerations

The enclosure may be painted. Please pay attention to the following considerations.

NOTE

Corrosion preventative coating has been applied to the enclosure. Standard degreasing practices must be followed before applying paint.

- Do not hinder the latches on the connector if the connector is painted.
- If the enclosure is painted before the sensor module(s) is added, be sure to mask off the area where the sensor module(s) will be placed. The module must mate directly to the enclosure with nothing between. Failure to do this will degrade the alignment of the system and may cause it to fail.
- Ensure excess paint runoff does not clog enclosure drain holes.

MECHANICAL INSTALLATION

3.0 56 C-Face / Bracket Mounting

Flexible couplings are generally used to couple the Model 6200 to its driver (NorthStar part number RIMFLEX5858). There are a wide variety of speeds, loads, environment, and alignment conditions found in various applications. If there is doubt to suitability, we recommend you consult the flexible coupling manufacturer on your particular application requirement. One simple design of coupling can not fulfill all potential applications or conditions.

1. Mount the C-Face adapter bracket (not supplied) onto the motor per manufacture's instructions. See Figure 3. Be sure the 4.5 inch C-Face is concentric to the motor shaft.
2. Insert flexible coupling onto the motor shaft. Do not tighten at this time.
3. Place the Model 6200 onto the 4.5 inch C-Face. Insert and tighten four 3/8-16 UNC bolts. Be sure it is seated flat against the mounting bracket.
4. Connect flexible coupling onto the Model 6200 shaft and tighten per manufacturer's specifications.
5. Rotate the shaft by hand to ensure free rotation.
6. Place or replace appropriate safety shields.

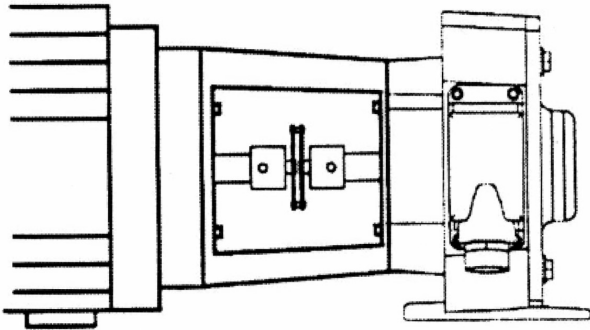

56C-Face / Bracket Mounting

3.1 Foot Mounting

Foot mounting brackets are included on the bottom of the Model 6200. The bolt hole pattern is slotted to permit a measure of adjustment. Flexible couplings are generally used to couple the Model 6200 to its driver (NorthStar part number RIMFLEX5858). There are a wide variety of speeds, loads, environment, and alignment conditions found in various applications. If there is doubt to suitability, we recommend you consult the flexible coupling manufacturer on your particular application requirement. A simple coupling design can not fulfill all potential applications or conditions.

1. Place the Model 6200 mounting bracket in the approximate final position.

NOTE: The mounting should be strong enough to sufficiently support the weight of the Model 6200 (approximately 25 pounds) without excessive deflection due to load or vibration. Deflection can cause erroneous outputs and shorten the operational life of the unit.

2. Insert, but do not tighten, four 5/16"-18 UNC bolts into the mounting bracket holes.
3. Insert and connect flexible coupling onto the motor and Model 6200 shaft per manufacture's specifications.

NOTE The life expectancy of the flexible coupling and Model 6200 are influenced by the accuracy to which the shafts are aligned in this step.

4. Tighten mounting bolts to nominal 30 foot-pounds.
5. Rotate shaft by hand to ensure free rotation.
6. Place or replace appropriate shields.

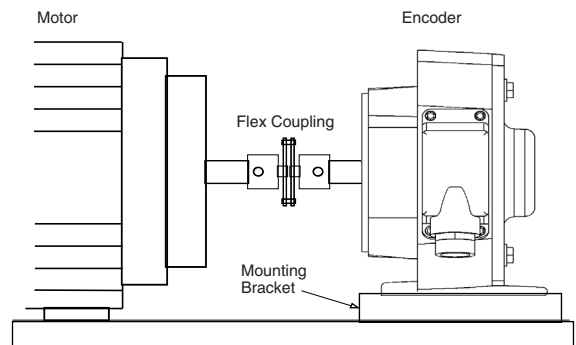

Foot Mounting

MECHANICAL INSTALLATION

3.2 Pulley Mounting

1. Mounting the Model 6200 onto mounting bracket with four 5/16"-18 UNC bolts through foot mounting bracket holes.

NOTE The mounting bracket should be strong enough to sufficiently support the weight of the RT 6200 (approximately 25 pounds) without excessive deflection of play due to load or excessive vibration. Deflection can cause erroneous outputs and shorten operational life of the unit.

2. Mount and connect 5/8 inch I.D. pulley on to the RT 6200 input shaft.

3. Install a tension belt according to the manufacturer's specifications. If the belt tension is too light it can cause pulley slippage or backlash, thereby creating an erroneous signal output. However, for maximum operational life of the Model 6200, a belt tension loading of less than 40 pounds should be used.

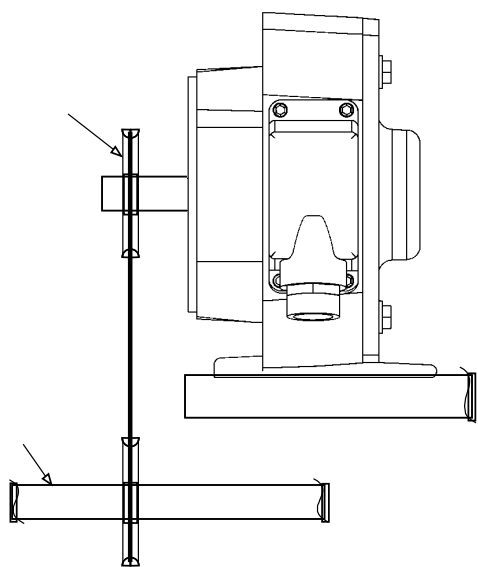

Pulley Mounting

4.0 Sensor Module Installation

To install the sensor Module, perform the following steps. See Figure, below.

1. Remove sensor module and mating connector from packaging. CAUTION! Although the device is protected from Electrostatic Discharges up to 2000 Volts, standard ESD precautions should be followed.

2. Separate mating connector from sensor module by releasing the two latches.

CAUTION! Use caution when handling the sensor module. The sensor at the end of the module can be easily damaged by sharp objects. The sensor module can be damaged by sudden shocks (dropping, hammer blows, etc.).

3. Insert sensor module into opening in enclosure. The sensor assembly is keyed to ensure proper orientation.

4. Locate four shoulder screws. Insert shoulder screws through clearance holes in sensor module and into tapped holes in enclosure. Tighten to a nominal 5 inch-pounds.

CAUTION! There should not be a gap between the lip on the housing and the enclosure. The stainless steel sensor module is designed to seat in metal to metal contact with the enclosure. Ensure that no gaskets, paint, dirt, etc., interferes with the complete seating of the module in the enclosure.

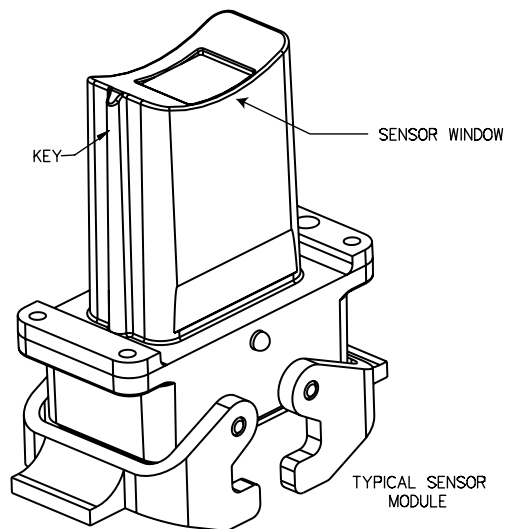

Sensor Module

ELECTRICAL INSTALLATION

5.0 Wiring

NOTE: Refer to “Important Installation Information” on pages 2 & 3 prior to wiring the encoder.

Electrical connections are made to the sensor module through a standard 1/2 inch NPT liquid tight flexible conduit. The nipple length may be changed to extend the outlet box if desired. Interconnection cable recommendations are as follows: stranded copper, 22 through 16 gage, braided or foil with drain wire shielding 0.05 mF maximum total mutual or direct capacitance, outer sheath insulated. Shrink tubing may be placed over any wires without insulation. For lengths over 100 feet, use 18 gage or larger, to a maximum of 1000 feet. If shielded twisted pair wire is used, do not cross channels. Keep each pair of complementary channel outputs together in a single twisted pair (e.g., A and \bar{A} complement).

ELECTRICAL CONNECTIONS

Signal	Connector Pin	Pigtail Cable	MS3102E18-1P
Common	1	Black	A
B	2	Green	E
A	3	Blue	D
Z *	4	Violet	C
N/C	5	—	—
Vcc	6	Red	B
\bar{B}	7	Yellow	H
\bar{A}	8	Gray	G
\bar{Z} *	9	Orange	I
Shield	10	Braid	J

* Index (Z) optional. See Ordering Information

5.1 Quick Release Connector Hood Wiring

To install the Quick Release Connector, perform the following steps.

1. Remove the four screws from the mating connector housing that hold the terminal block in place. Remove terminal block from housing.
2. Insert wiring through liquid tight flexible seal and mating connector housing. Leave enough wire exposed to comfortably reach the terminal block. Wire to terminal block according to wire code in Table 1. A similar wiring list is attached to enclosure.

NOTE There are two orientations of the connector hood. The terminal block can be inserted either way so the connector hood points up or down. Choose the direction best for your application.

4. Tighten Liquid Tight fitting on housing. **OPTIONAL:** In some hostile environments, seal between connector body and Sensor Module can be improved by smearing a sealant (silicone grease, etc.) on the neoprene seal of the connector.

5. Mate connector into place on sensor mount and snap the two latches into place. If only one sensor is being installed, ensure cover plate is installed over other sensor hole.

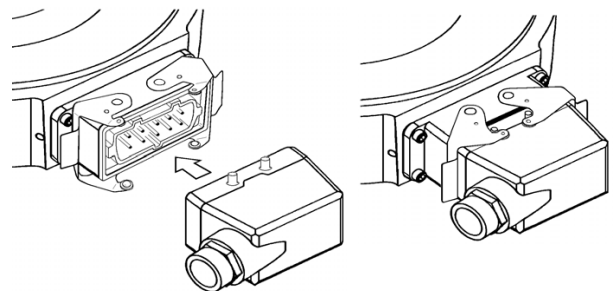
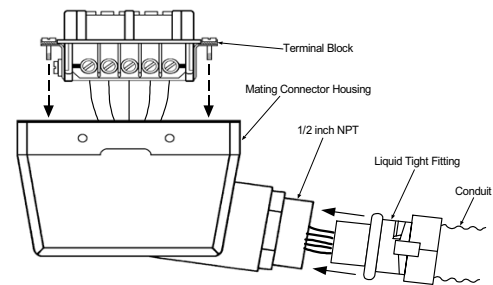

Quick Release Hood Wiring

Ordering Information

To order, complete the model number with code numbers from the table below:

Code 1: Model	Code 2: PPR	Code 3: Index	Code 4: Shaft	Code 5: Electrical	Code 6: Termination	Code 7: Options
RT6	□□□□	□	□□□	□	□	□
Ordering Information						
RT6 Foot Mount and Close Coupled Housing	0060 0480 0064 0512 0075 0600 0120 0960 0128 1024 0150 1200 0240 1920 0256 2048 0300 2400 4096	L No Index Z With Index Signal Output	A Single Shaft Stainless Steel 5/8" B Dual Shaft Stainless Steel 5/8" S Single Shaft Hi-strength Steel 5/8" D Dual Shaft Hi-strength Steel 5/8"	1 5-26VDC in, 5-26VDC Line Driver out (IC-WE), Single output 2 5-26VDC in, 5-26VDC Line Driver out (IC-WE), Dual output	C Latching Industrial Connector F Latching Industrial Connector without Mating Connector M 10 pin MS Connector P 18" Long Pigtail Cable Q Latching Industrial Connector On 18" Cable R Latching Industrial Connector On 18" Cable without Mating Connector	Blank No Option GB Shaft Grounding Brush (Code 4 must be S)

Note: See ACCESSORIES Section For Connectors, Grounding Brushes, Spare Parts and Pulse Wheels

