

NorthStar™

NorthStar Mill-Duty Digital Tachometers RIM Tach® 8500 NexGen



A mill-duty encoder that
keeps you ahead of the curve

**Same mill-duty rugged design
your applications demand:**

- Ductile "fully coated"
Cast Iron Housings
- Stainless Steel Replaceable
Sensor Modules
- Fully Encapsulated Electronics
- Best In Class Durable
Wheel Options

Redesigned With:

- The Most Rugged Magnetic
Technology Available Today
- Largest Non-Contact Sensing
Gap Available On The Market
- Higher Resolutions to 2048 PPR
and (4096 COMING SOON)
- Active LED Indicator
With Diagnostics

NorthStar – Pioneers of proven magnetic digital tachometers, remains committed to developing new and reliable products, delivering quality, and outstanding service to our industrial customers.



The next generation of RIM Tach encoders has arrived

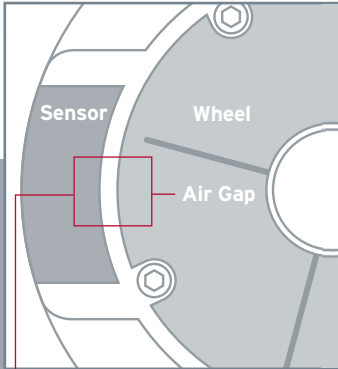

NorthStar RIM Tach 8500®
NexGen's curved sensor head features the largest gap on the market

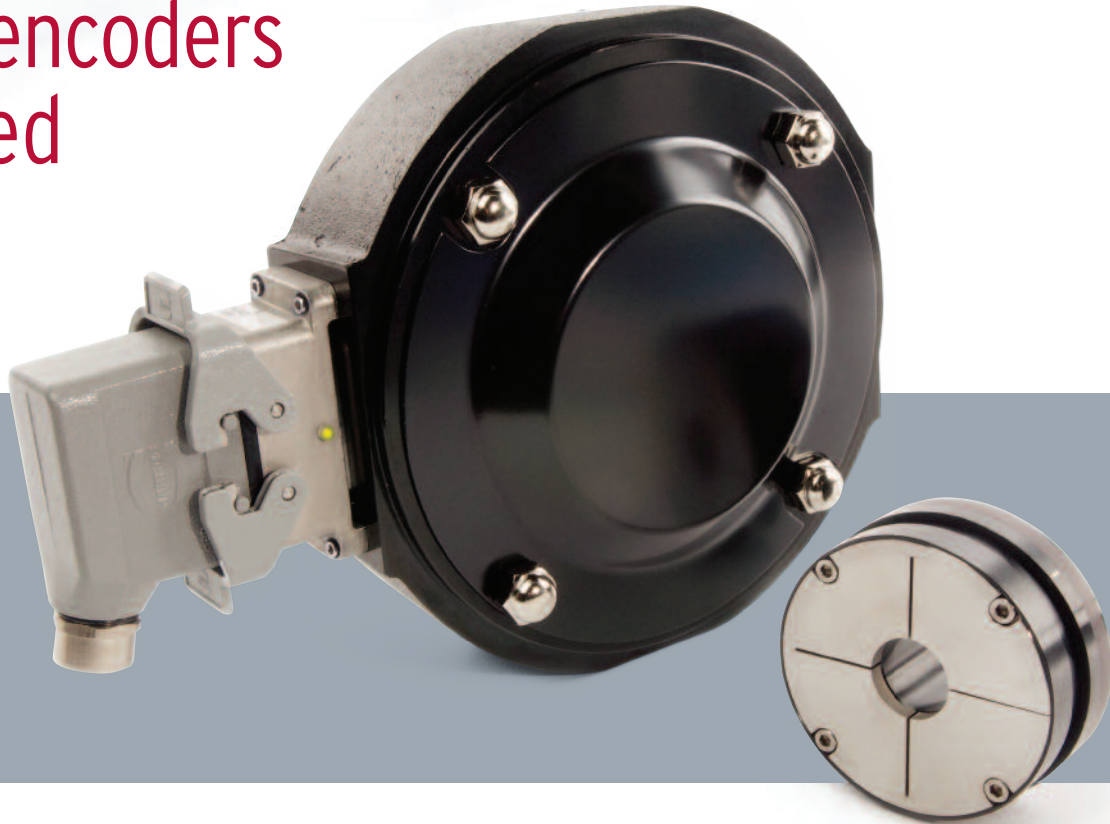

The RIM Tach product line was specifically designed over 20 years ago to provide high performance velocity and position feedback for AC and DC motor and drive control systems. The demands today require more forgiving installation to accommodate for variations in shaft concentricities, C-face bracket fits, and higher resolutions to meet the demands of today's high performance drives. The result is the NorthStar RIM Tach 8500 NexGen encoder.

Features

Largest non-contact sensing gap (70 thousandths) available on the market.

Higher resolutions to 2048 and (4096 COMING SOON) with strong clear signal output.

Active LED with troubleshooting diagnostics.

NEW wheel lock design.

Protective magnetic wheel edge guard.

NexGen RIM Tach sensor module and wheel are reverse compatible with previous generations RIM Tach series.

Benefits

Quick easy installation on vector motors. No precision tools or measurements required. More generous axial play (up to 1/2") when aligning wheel to sensor. More forgiving in tough applications where brakes and dynamic shaft deflections typically cause wheel to sensor strikes.

More reliable signal for demanding applications and higher performance drives.

Precise troubleshooting during installation and operation, preventing unscheduled downtime.

Industry leading wheel design positively locks to the shaft without damaging the shaft.

Protects magnetic surface on the wheel from rough handling.

Take advantage of today's new technology and benefits and upgrade existing installations by just replacing the sensor module and wheel. Saves money by not having to replace old housings and hardware.



US Headquarters

1675 Delany Road • Gurnee, IL 60031-1282 USA • Toll-Free: 800-873-8731 • Phone: 847-662-2666 • Fax: 847-662-6633 • www.dynapar.com