

NorthStar Instruction Manual Supplement

Sensor Module installation for high humidity/wash-down and marine environments.

Slim Tach Series SL56, RL67, SL85, SL1250 and HS56

RimTach Series 8500, 1250, 6200, and HS85

Dynapar uses the highest quality electrical connectors available on the market today. They have long met tough industrial protection requirements of IP65 & IP68 according to IEC 60529. In tough marine, outdoor and coastal environments where humidity levels are high, these connectors can still experience ingress of moisture through condensation buildup, causing corrosion and electrical shorts. Typically the only way to alleviate the problem is with a drain or weep hole, which is not optimum when these connectors are installed in a variety of positions.

NorthStar recommends the use of a high Dielectric strength, low volatility moisture resistant grease with good thermal oxidation and chemical stability. The grease should be applied to the contact pins, disconnection junctions and internal cavity of the connector. It can be applied by hand, brushing or wiping. When applied per NorthStar instructions, it will provide a moisture proof seal, and prevent oxidation of bare metal pins.

INDUSTRIAL LATCHING CONNECTORS

Remove the 4 terminal block screws from the mating connector housing. Remove the terminal block from mating connector housing. (See figure)

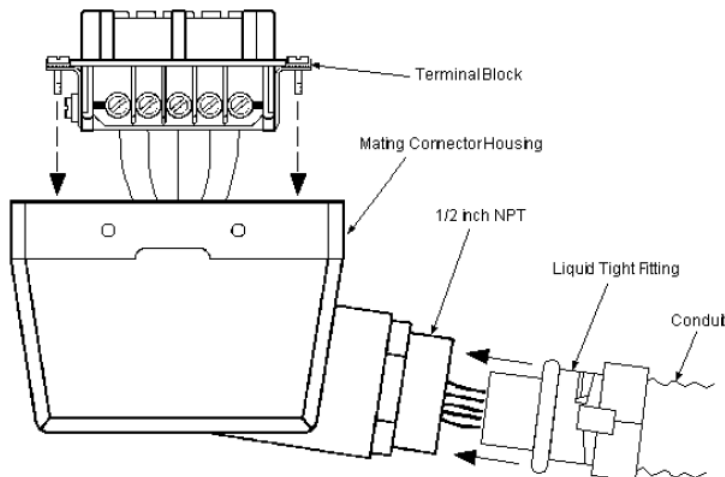

Insert wiring through liquid tight flexible seal and mating connector housing. Leave enough wire exposed to comfortably reach the terminal block. Wire to terminal block according to wire code in general instructions.

Pack the rear of the terminal block and mating connector housing full with NorthStar supplied di-electric grease and re-install the terminal block into the mating connector housing.



The connector hood has two orientations. The terminal block can be inserted either way so the connector hood points up or down. Choose the direction best for your application. The shield in the sensor module is isolated from the frame of the encoder for maximum noise immunity. The shield wire or pin should be connected to the shield on the drive.

Secure the 4 terminal block screws and tighten the liquid tight fitting on the mating connector housing.

Pack both sides of the terminal block and open voids between the terminal block and housing. Connect the mating connector to base and snap the two latches into place. (See figure)

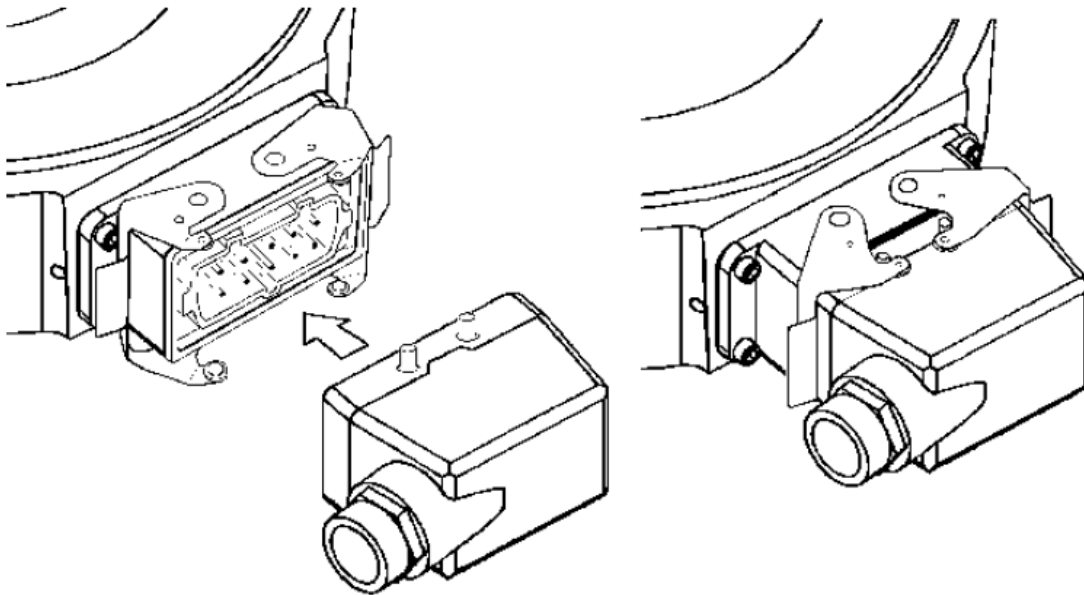

1675 Delany Road • Gurnee, IL 60031

Phone: +1.800.873.8731 (toll-free) • 847.662.2666 • Fax: 847.662.6633

Email: custserv@dynapar.com; northstar.techsupport@dynapar.com

www.dynapar.com