

NorthStar[™] brand

Instruction Manual

RIM Tach[®] 1250 Digital Tachometer

Designed for use in
0.625"-8.00" Outer Diameter Thru-Shaft Applications



Customer Service:
Tel.: +1.800.873.8731
Fax: +1.847.662.4150
custserv@dynapar.com

Technical Support
Tel.: +1.800.234.8731
Fax: +1.847.782.5277
northstar.techsupport@dynapar.com

Website: www.dynapar.com

791-1004-00

Table of Contents

Chapter/Paragraph/Illustration	Page
1 Introduction.....	4
1.0 Safety Summary.....	4
1.1 General.....	5
1.2 Descriptions	5
<i>Figure 1: Small Thru-Shaft Enclosure</i>	<i>5</i>
<i>Figure 2: Specification Drawing</i>	<i>6</i>
1.3 Specifications.....	6
2 Installation.....	7
2.0 Inspection and Unpacking	7
2.1 Painting Considerations	7
2.2 Mechanical Installation.....	7
<i>Figure 3a: Large Thru-Shaft 1250</i>	<i>7</i>
<i>Figure 3b: Large Thru-Shaft Assembly</i>	<i>8</i>
2.2.1 Motor Facing and Shaft	8
<i>Figure 4: Typical 12.5 Inch Diameter Type C-Face Motor</i>	<i>9</i>
2.2.2 Pulse Wheel Assembly for Small and Large Thru-Shaft.....	9
<i>Figure 5: Pulse Wheel Assembly</i>	<i>10</i>
2.2.3 High Slew Rate Wheels	10
<i>Figure 6: High Slew Rate Wheel</i>	<i>10</i>
2.2.4 Enclosure Installation	11
2.2.5 Pulse Wheel Assembly Axial Position Adjustment.....	12
<i>Figure 7: Pulse Wheel Alignment Check Using Straight Edge</i>	<i>12</i>
2.2.5.1 Optional Pulse Wheel Alignment Check	12
<i>Figure 8: Optional Pulse Wheel Alignment Check w/ Depth Gauge.....</i>	<i>12</i>
2.2.6 Sensor Module Installation	13
<i>Figure 9: Sensor Module Installation.....</i>	<i>13</i>
2.3 Electrical Installation	13
2.3.1 Quick Release Connector Hood Wiring	14
<i>Figure 10: Quick Release Connector Installation.....</i>	<i>14</i>

Methods and apparatus disclosed and described herein have been developed solely on company funds of Dynapar. No government or other contractual support or relationship whatsoever has existed which in any way affects or mitigates proprietary rights of Dynapar in these developments. Methods and apparatus disclosed herein may be subject to U.S. Patents existing or applied for. Dynapar reserves the right to add, improve, modify, or withdraw functions, design modifications, or products at any time without notice. Dynapar shall not be liable for errors contained herein or for incidental or consequential damages in connection with furnishing, performance, or use of this material.

CHAPTER 1

INTRODUCTION

1.0 Safety Summary

High current, voltage, and rotating parts can cause serious or fatal injury. The use of electric machinery, like all other uses of concentrated power and rotating equipment, may be hazardous. Installing, operating, and maintaining electric machinery should be performed by qualified personnel, in accordance with applicable provisions of the National Electrical Code and sound local practices. Failure to comply with these precautions or with specific warnings elsewhere in this manual violates safety standards of design, manufacture, and intended use of the instrument. Dynapar assumes no liability for the customer's failure to comply with these requirements.

Rotating Machinery

Avoid contact with rotating parts. Avoid by-passing or rendering inoperative any safety guards or protection devices. Avoid extended exposure in close proximity to machinery with high noise levels. Use proper care and procedures in handling, lifting, installing, operating and maintaining the equipment.

Before Installation

Safe maintenance practices with qualified personnel is imperative. Before starting maintenance procedures, be positive that, (1) equipment connected to the shaft will not cause mechanical rotation, (2) main machine windings have been disconnected and secured from all electrical power sources, and (3) all accessory devices associates with the work area have been de-energized. If high potential insulation test is required, follow procedures and precautions outlined in NEMA standards MG-1.

Grounding

Improperly grounding the frame of the machine can cause serious or fatal injury to personnel. Grounding of the machine frame and structure should comply with the National Electrical Code and with sound local practices. Check wiring diagram before connecting power.

Do Not Operate In An Explosive Atmosphere

Do not operate the instrument in the presence of flammable gases or fumes. Operating any electrical instrument in such an environment constitutes a definite safety hazard.

Keep Away From Live Circuits

Operating personnel must not remove instrument covers. Component replacement and internal adjustments must be made by qualified maintenance personnel. Do not replace components with power cable connected. To avoid injuries, always disconnect power and discharge circuits before touching them.

Do Not Substitute Parts Or Modify Instrument

Do not install substitute parts or perform any unauthorized modification to the instrument. Introducing additional hazards is dangerous. Return the instrument to an authorized Dynapar representative for service and repair to ensure that safety features are maintained.



CAUTION!: Crucial information that *must* be read and followed regarding product functioning and safety.



DO THIS!: Additional procedure that must be read and followed for proper operation, without safety concerns.



NOTE: Useful information.



QUESTION: Helpful hints to answer your possible questions.

1.1 General

These instructions do not claim to cover all details of variation in equipment or to provide for every possible contingency or hazard to be met in connection with installation, operation, and service. Should further information be desired or should particular problems arise which are not covered sufficiently for the purchaser's purposes, please contact Dynapar, or one of its designated representatives.

1.2 Description

The RIM Tach® 1250 is a high performance, reliable Digital Tachometer, designed to provide position and velocity feedback from both AC and DC electric motors with pulse counts ranging from 60 through 2048 pulses per revolution. Designed for NEMA 12.5 inch diameter type C-face motor frames, the RIM Tach 1250 utilizes rugged ductile iron casting construction, and provides interchangeable sensor modules and a magneto-resistive technology capable of withstanding the harshest industrial environments. This ensures a precise and consistent digital motor speed feedback.

The NorthStar RIM Tach® 1250 is mounted directly to the motor frame and utilizes a patent pending, heavy-duty, one piece, magneto-resistance sensor module with encapsulated surface mount electronics. The encapsulation provides resistance to water, oil mist, dirt, high temperatures, and other harsh environments. The sensor module includes a 10-pin quick connector requiring only a screwdriver for final electrical installation. The non-contact magneto-resistive sensor and rugged magnetized pulse wheel are designed and machined to function properly without any adjustments when assembled to Type C-Face (12.5-inch diameter) motor frame and accessory mount. There are no bearings to fail or requirements for flexible couplings since the magnetized pulse wheel assembly is attached directly to the shaft.

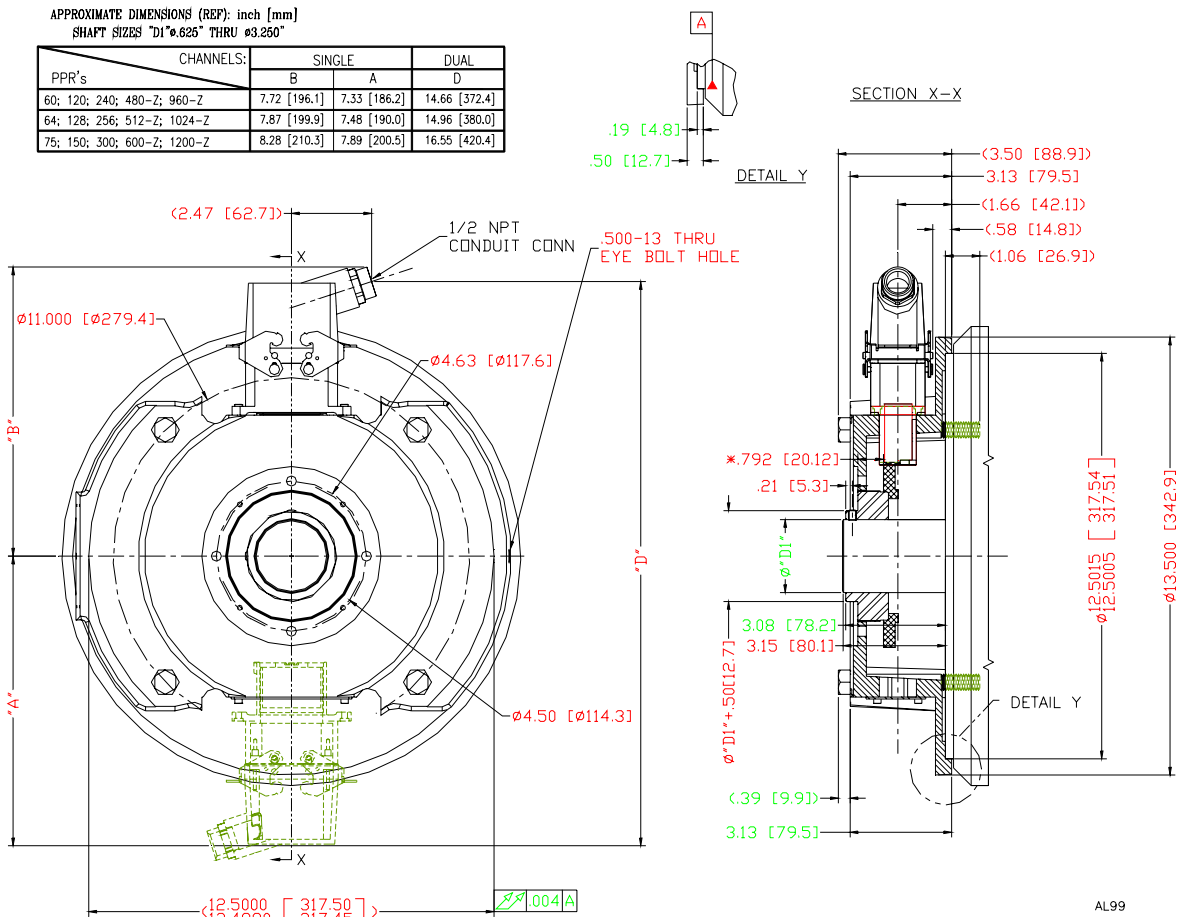

Figure 2: RIM Tach® 1250 Specification Drawing

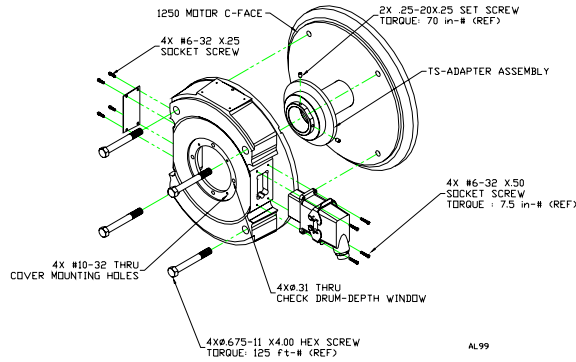

Figure 1: RIM Tach 1250 Small Thru-Shaft Enclosure

1.3 Specifications (subject to change without notice).

Electrical Specifications	
Frequency Response	120 kHz
Pulse Code	A, B, Z (Index), and compliments (A, B, Z)
Output Phases	A phase, B phase @quadrature: 90° phase, Z phase: Once per rev. (gated)
Pulse Duty Cycle	50 ± 15% (within defined mechanical specifications)
Quadrature Accuracy	90 ± 22% (within defined mechanical specifications)
Output Type	High speed, differential driver
Rise and Fall Time	Less than 1µs @ 10,000 pf typical load
Current Consumption	45 mA typical plus line driver load
Output Current	150 mA maximum continuous
ESD Protection	2kV
Mechanical Specifications	
Maximum Operational Speed	7,000 RPM or 120 kHz
Nominal Air Gap	0.019 ± 0.008"
Shaft Axial End Play	Up to ± 0.050"
Maximum Operational Speed	7,000 RPM (120khz)
Enclosure Configuration	12.5" motor face or accessory flange to meet NEMA MG1-4 standards
Acceleration Rate	3,600 RPM/sec (12,000 RPM/sec) with optional high slew rate pulse wheel
Enclosure Material	Ductile iron casting
Sensor Module	Stainless steel
Unit Dimensions / Weight	21" (534mm) x 15" (381mm) x 12" (305mm) / 35lbs. (16 kg.)
Box Dimensions / Weight	24" (610mm) x 15.5" (394mm) x 15.25" (388mm) / 2 lbs. (1 kg.)
Environmental Specifications	
Operational Temperature	-40° to +80° C
Operational Humidity Range	Maximum of 90%
Chemical Resistance	Salt spray, most solvents, mild acids and bases
Vibration	Minimum 18 g's RMS, 5-2000 Hz
Shock (Sensor Module)	1 meter drop tested, min. 30g's
Interface Specifications	
Power	+5.0 to +15.0 VDC
Output	Differential output swinging between Vcc - 0.6V and ground
Connector	10 pin industrial latching connector with ½" NPT fitting, IP-65 NEMA 4, 12 rated
Suggested Cable	22 - 16 AWG, 10 conductor , shielded, twisted pair

CHAPTER 2 INSTALLATION

2.0 Inspection and Unpacking

Inspect shipping container for external damage. All claims for damage (apparent or concealed) or partial loss of shipment must be made in writing to Dynapar within (5) days from receipt of goods. If damage or loss is apparent, please notify the shipping agent immediately.

Open shipping container and locate the packing list. The packing list is included to verify that all components, accessories, and manual were received. Please use the packing list to check off each item as the unit is unpacked. Inspect for damage. We recommend that the shipping container be retained for future shipping, storage, or return to factory purposes. Dynapar cannot be responsible for any missing parts unless notified within 60 days of shipment.

2.1 Painting considerations

The enclosure may be painted. Please pay attention to the following considerations.



Corrosion preventative grease has been applied to the enclosure. Standard degreasing practices must be followed before applying paint.

- Do not hinder the latches on the connector if the connector is painted.
- If the enclosure is painted before the sensor module(s) is added, be sure to mask off the area where the sensor module(s) will be placed. The module must mate directly to the enclosure with nothing between. Failure to do this will degrade the alignment of the system and may cause it to fail.
- Ensure excess paint runoff does not clog Enclosure drain holes.

2.2 Mechanical Installation

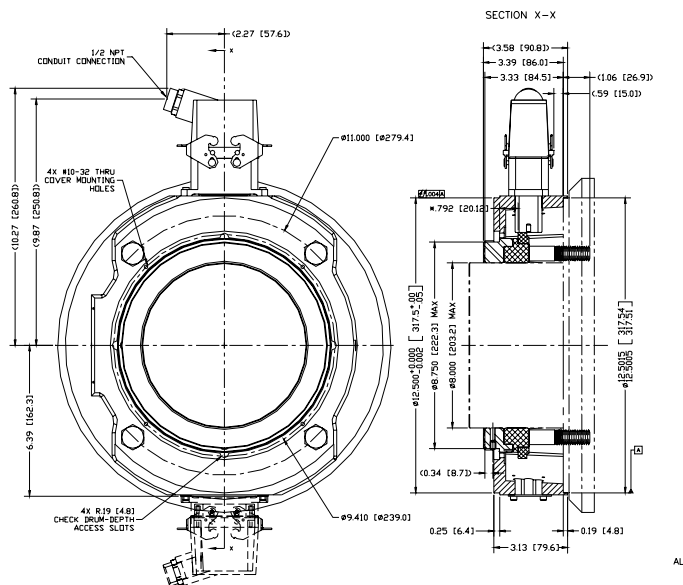

Figure 3a: Large Thru-Shaft 1250

The RIM Tach 1250 utilizes a modular construction, allowing the user to configure the unit as a one or two signal output tachometers. Sensor modules are universal and interchangeable. If one output requires replacement, simply remove four screws, and replace with a new sensor module. No electrical adjustment or alignment is required. Also, you never have to remove the RIM Tach 1250 enclosure from the motor. Other devices such as brakes or gear reducers mounted from the RIM Tach 1250 do not need to be removed. After unpacking the unit and verifying receipt of the items listed on the packing list, you may proceed with mechanical installation.

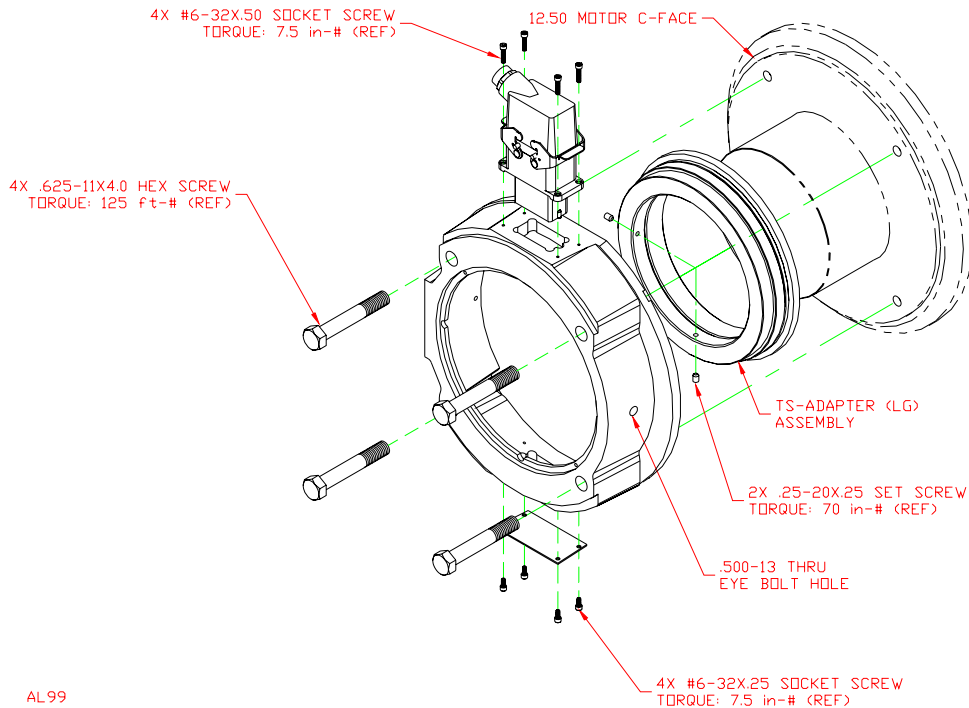

Figure 3b: Large Thru Shaft Assembly

2.2.1 Motor Facing and Shaft

To prepare the motor facing and shaft for installation, perform the following steps. See Figure 4.

1. Clean outer rim and surface of motor facing and shaft of paint, grease, dirt, and other debris where RIM Tach 1250 unit contracts motor or accessory. Also ensure that mating surfaces have not been damaged and that unit will fit squarely on motor.



Ensure there is no paint, burrs, protrusions, or deformations on the motor facing or shaft. If the enclosure does not fit squarely on the motor facing, the alignment between the sensor module and the magnetic pulse wheel may be degraded.

2. Apply a thin layer of corrosion preventative or oil to motor facing and shaft to aid assembly.



The pulse wheel must be well attached during rapid acceleration or deceleration of the shaft. The installer may elect to drill the set screw holes before installing the enclosure. Alternatively, the installer may elect to install the enclosure, measure, then remove the enclosure before drilling. Continue with Steps 3 through 5 if electing to predrill set screw holes. If not, proceed to 2.2.2 and continue with the installation procedure.

3. The pulse wheel assembly uses two set screws to hold the unit in place. These holes are at 90 degrees to each other and located 2.316 ± 0.005 inches from the motor facing.
4. Locate three holes using appropriate measuring equipment.
5. Use standard 17/64 inch bit to drill a hole that is 0.09 to 0.11 inches deep from the tangent point of the shaft (point of first contact of the drill to the shaft) to the bottom of the hole. Do this for both holes.

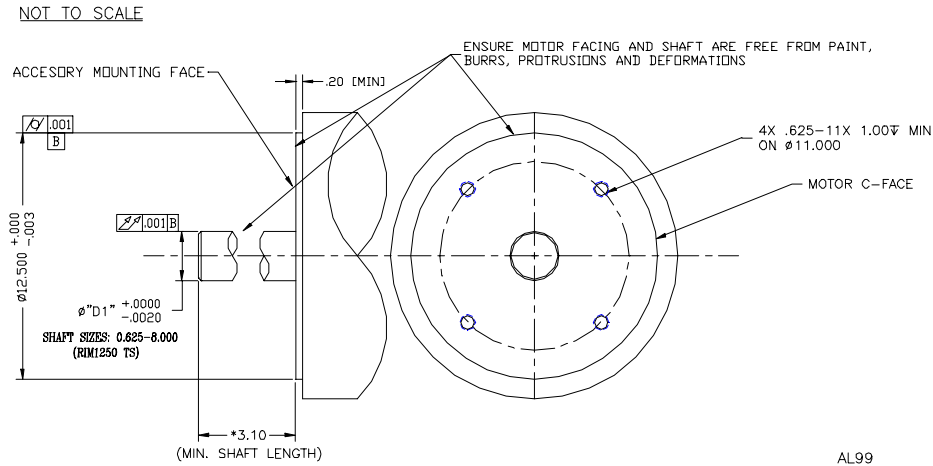

Figure 4: Typical 12.5 Inch Diameter Type C-Face Motor

2.2.2 Pulse Wheel Assembly for Small and Large Thru-shaft

To prepare the pulse wheel assembly for installation, perform the following steps. See Figure 5.



Caution must be used when handling the pulse wheel assembly. The surface of the pulse wheel outer rim is sensitive to scratches and impacts. The magnetic properties of the pulse wheel material can also be distorted or erased by exposure to strong magnetic fields.

1. Remove pulse wheel assembly from packaging.
2. Leave protective red rubber band in place over pulse wheel.
3. Place assembly over the end of the shaft. The wheel side with the two set screws should be toward the outside, away from motor.



Be sure the set screws in the adapter are retracted so that they will not interfere with the shaft while mounting the unit.

4. Slide assembly on the shaft until there is about a 1 inch gap left between inner face of pulse wheel and motor facing. It may be necessary to lightly tap the assembly to get it all the way on. The 1 inch gap is not a critical measurement.



Tap on the steel hub; not on the silver-colored aluminum magnetic wheel.

5. If you have already drilled set screw locating holes, align unit to holes and tighten set screws to a nominal 15 inch-pounds. If you will not be using set screw locating holes or wish to use alternate method of adding them, just leave assembly in place and continue to the **Enclosure Installation**.

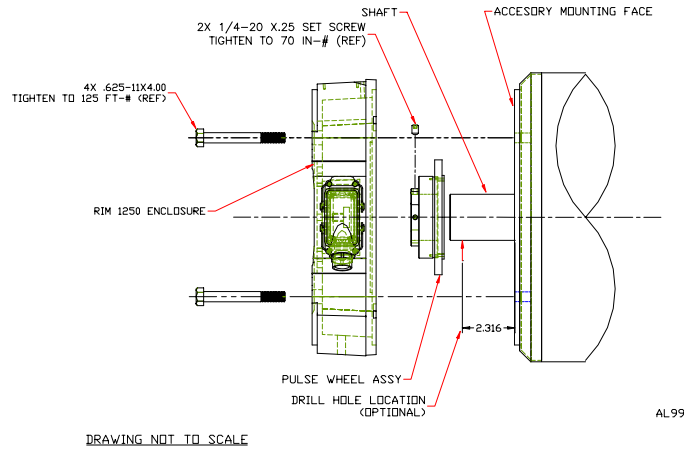

Figure 5: Pulse Wheel Assembly

2.2.3 High Slew Rate Wheels

The following section discusses how to mount a high slew rate wheel (refer to Figure 6).

1. Loosen the screws around the outer portion of the wheel to approximately .030 inch gap. This will allow the inner diameter ring enough space to move out of the way of the shaft. Do not to open the gap too far or the ring will move out of the pocket it sits in.
2. Place the pulse wheel over the end of the shaft. The pulse wheel will stop at the ring. With a pen (or some other object that will not damage the shaft) work the ring around the shaft into the groove in the wheel. The wheel should then completely slide on the shaft.
3. Place the housing on the motor using the four 0.625"-11 mounting hex cap screws. Bolt the housing to the motor. Align the pulse wheel so that it is flush with the alignment surface of the housing.
4. Finally, tighten down the pulse wheel mounting bolts in a star pattern.



NorthStar recommends that if a brake is going to be used in conjunction with the encoder, the encoder must use a high slew rate wheel. NorthStar considers <3600 RPM per second acceleration or deceleration of the shaft to be a high slew rate wheel application.

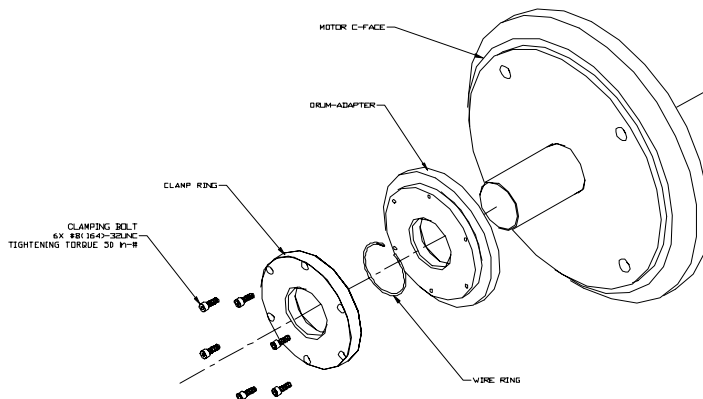

Figure 6: High Slew Rate Wheel

2.2.4 Enclosure Installation



Do not attempt to mount or dismount the enclosure with sensor probe module(s) installed. Remove all sensor modules until enclosure mounting is complete.

1. Remove red rubber band from pulse wheel. If test fitting the enclosure, leave rubber band in place until final enclosure mounting.
2. Remove enclosure from packaging.
3. Determine which of two orientations of enclosure is best for this application (Sensor Modules horizontal or vertical).



If mounted horizontally, ensure that the drain hole is at bottom of enclosure. If not, rotate the unit 180°.

5. Place enclosure onto motor C-facing.



Do not damage the pulse wheel when mounting the enclosure. If the pulse wheel assembly is not far enough down the shaft, continue pushing it on with the enclosure until the enclosure seats.

6. Tap lightly with hand or hammer if needed to make the enclosure slide over motor facing. Make sure clearance holes remain aligned.
7. Insert four 0.625"-11 hex cap screws onto the motor enclosure. If the enclosure has not already seated against the motor facing, do so by tightening the first bolt and then the bolt on the opposite side. Continue alternating and tightening until enclosure is seated. Torque all bolts to a nominal 125ft-lbs (see Figure 5).

2.2.5 Pulse Wheel Assembly Axial Position Adjustment

If the pulse wheel is not lined up and no pre-drilled holes are required, use the following procedure to adjust the position of the pulse wheel assembly. See Figure 4-6.

1. Slide pulse wheel assembly until the alignment surface of the unit is even with recess in face of enclosure. See Figure 2-3 for a detailed drawing of the pulse wheel assembly.
2. Use a straight edge to check it.
3. Loosen two set screws and slide pulse wheel along the shaft until the recess and wheel surfaces are aligned to within ± 0.010 inch.
4. Tighten two set screws to a nominal 70 in-lbs.

If the pulse wheel is not lined up and pre-drilled holes are desired, use the following optional procedure to locate (or relocate) set screw holes in the shaft.



If pre-drilled screw holes turn out to be incorrectly placed, new screw holes must be drilled. New holes may be drilled plus or minus the error distance from the old holes.

1. Leaving one set screw tightened, remove other set screw and use a punch to mark position of set screw hole on shaft.
2. Replace and tighten set screw. Remove other set screw and use a punch to mark position of that set screw hole on shaft.
3. Remove enclosure and pulse wheel.
4. Use standard 1/4" drill to drill a hole that is approximately 0.1" deep from tangent point of shaft (point of first contact of drill to shaft) to bottom of hole. Do this for both holes.
5. Reassemble pulse wheel and tighten set screws to a nominal 70 in-lbs.
6. Reassemble enclosure onto motor facing.

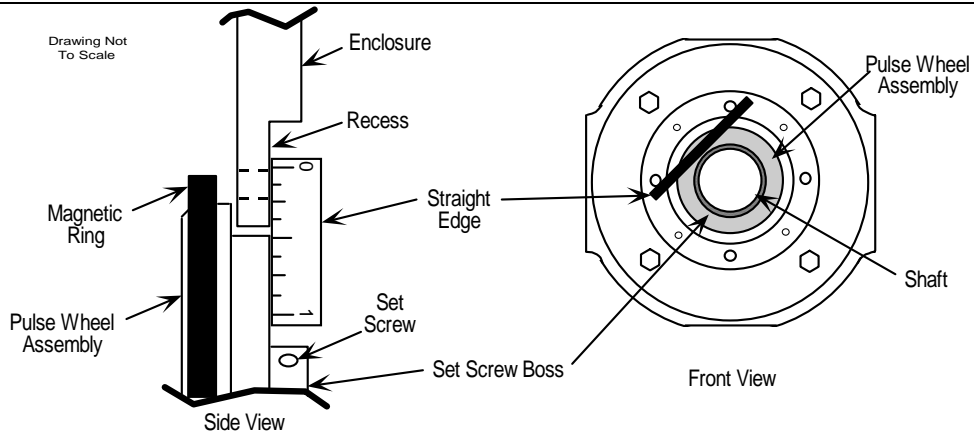

Figure 7: Pulse Wheel Alignment Check Using Straight Edge

2.2.5.1 Pulse Wheel Alignment Check

An optional and more accurate pulse wheel alignment check procedure is provided as follows. See Figure 7.

1. Locate four 5/16-inch diameter access holes on recessed area in the face of the enclosure. Access holes are located on a 4.63 diameter Bolt Center (BC).
2. Using a calibrated depth measuring tool (depth gauge, vernier caliper, etc.), measure through access hole to obtain distance between recessed surface on enclosure and aluminum magnetic ring underneath.



Ensure the gage is measuring the distance to the flat surface of the aluminum magnetic ring and has not engaged the edge of the steel hub or slipped past the edge of the pulse wheel.

3. Repeat for all four access holes. Take an average of all four readings.



The range (difference between high and low measurements) of readings should be less than 0.005 inch. If the range of the readings is greater, than this, the pulse wheel is not perpendicular to the shaft and will appear to wobble during shaft rotation. Tap the edge of the pulse wheel to bring it back in line.

4. The distance between surface of the recess in the face of the enclosure and silver aluminum magnetic ring should be 0.792 ± 0.010 inch. Otherwise, the position of the pulse wheel assembly should be adjusted. Refer to Paragraph 2.6 for information on adjusting axial position of pulse wheel assembly.

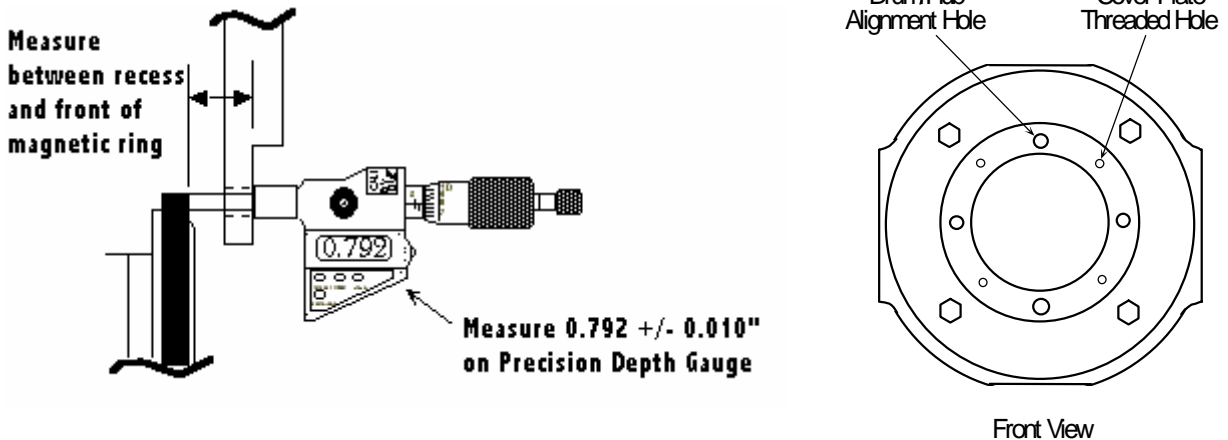

Figure 8: Optional Pulse Wheel Alignment Check w/ Depth Gauge

2.2.6 Sensor Module Installation

1. Remove sensor module and mating connector from packaging.



Although the device is protected from Electrostatic Discharges up to 2000 Volts, standard ESD precautions should be followed.

2. Separate mating connector from sensor module by releasing the two latches.



Use caution when handling the sensor module. The sensor at the end of the module can be easily damaged by sharp objects. The sensor module can be damaged by sudden shocks (dropping, hammer blows, etc.).

3. Insert sensor module into opening in enclosure. The sensor assembly is keyed to ensure proper orientation (blue side goes toward motor facing).
4. Locate socket head screws. Insert the screws through clearance holes in sensor module and into tapped holes in enclosure. Tighten to a nominal 7.5 in-lbs.



There should not be a gap between the lip on the housing and the enclosure. The stainless steel sensor module is designed to seat in metal to metal contact with the enclosure. Ensure that no gaskets, paint, dirt, etc., interferes with the complete seating of the module in the enclosure.

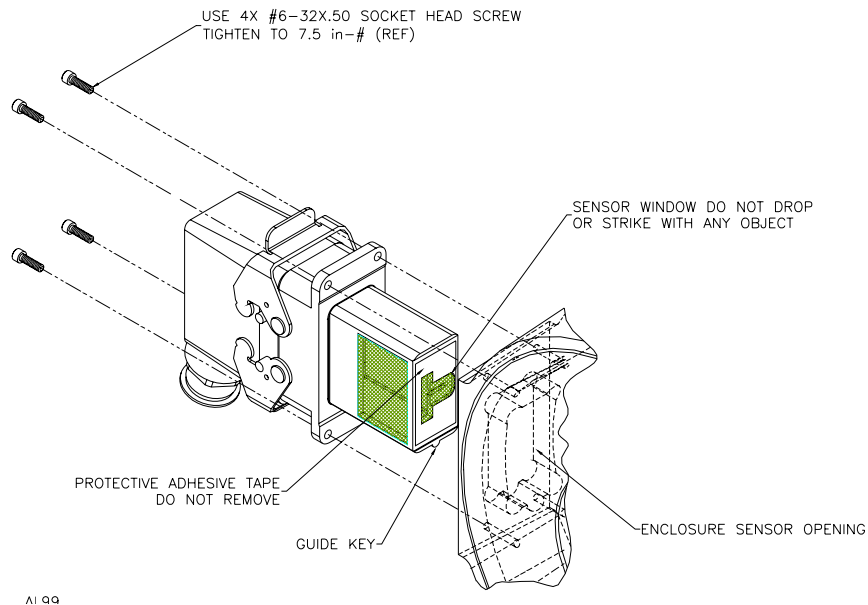

Figure 9: Sensor Module Installation

2.3 Electrical Installation

Electrical connections are made to the sensor module through a standard 1/2 inch NPT liquid tight flexible conduit. The nipple length may be changed to extend the outlet box if desired. Interconnection cable recommendations are as follows: stranded copper, 22 through 16 gage, braided or foil with drain wire shielding 0.05 μ F maximum total mutual or direct capacitance, outer sheath insulated. Shrink tubing may be placed over any wires without insulation. For lengths over 100 feet, use 18 gage or larger, to a maximum of 1000 feet. If shielded twisted pair wire is used, do not cross channels. Keep each pair of complementary channel outputs together in a single twisted pair (e.g., A and A).



Reversing power and common will not damage the unit. However, applying power to any of the sensor outputs may cause damage.

Signal	Connector Pin	Pigtail Cable	MS 3102E18-IT#
Common	1	Black	A
B	2	Green	E
A	3	Blue	D
Z *	4	Violet	C
No Connection	5	-----	-----
Vcc (5-15 VDC)	6	Red	B
/B	7	Yellow	H
/A	8	Gray	G
/Z *	9	Orange	I
Shield	10	Braid	J

* Applies only to units with index pulse capability.
 # Pinouts are for the sensors with the MS 3102E18IT connector



The shield in the sensor module is isolated from the frame of the encoder for maximum noise immunity. Connect the shield wire or pin to the shield of the cable and that of the drive or other receiving device.

2.3.1 Quick Release Connector Hood Installation

1. Remove the four screws from the mating connector housing that holds the terminal block in place. Remove terminal block from housing.
2. Insert wiring through liquid tight flexible seal and mating connector housing. Leave enough wire exposed to comfortably reach the terminal block. Wire to terminal block according to wire code in Table 1. A similar wiring list is attached to enclosure.



There are two orientations of the connector hood. The terminal block can be inserted with either the connector hood up or down. Choose the best direction for your application.

4. Tighten Liquid Tight fitting on housing. **OPTIONAL:** In some hostile environments, seal between connector body and Sensor Module can be improved by smearing a sealant (silicone grease, etc.) on the neoprene seal of the connector.
5. Mate connector into place on sensor mount and snap the two latches into place. If only one sensor is being installed, ensure cover plate is installed over other sensor hole.

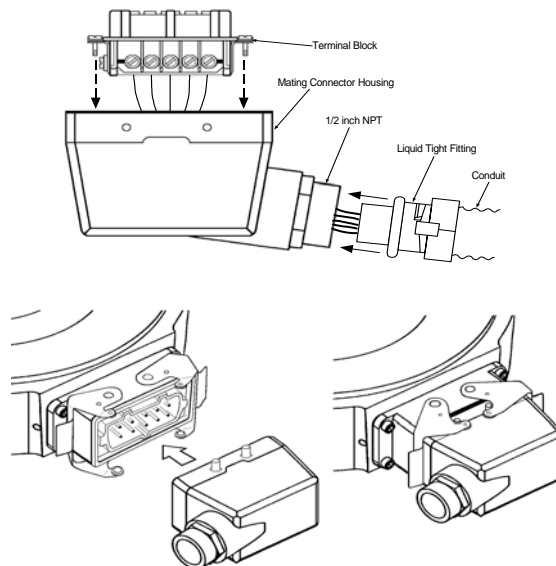

Figure 10: Quick Release Connector Installation