

REV	ECN	DATE	APPROVED
A	33001	11/14/12	AJ
B	33126	01/25/13	AJ

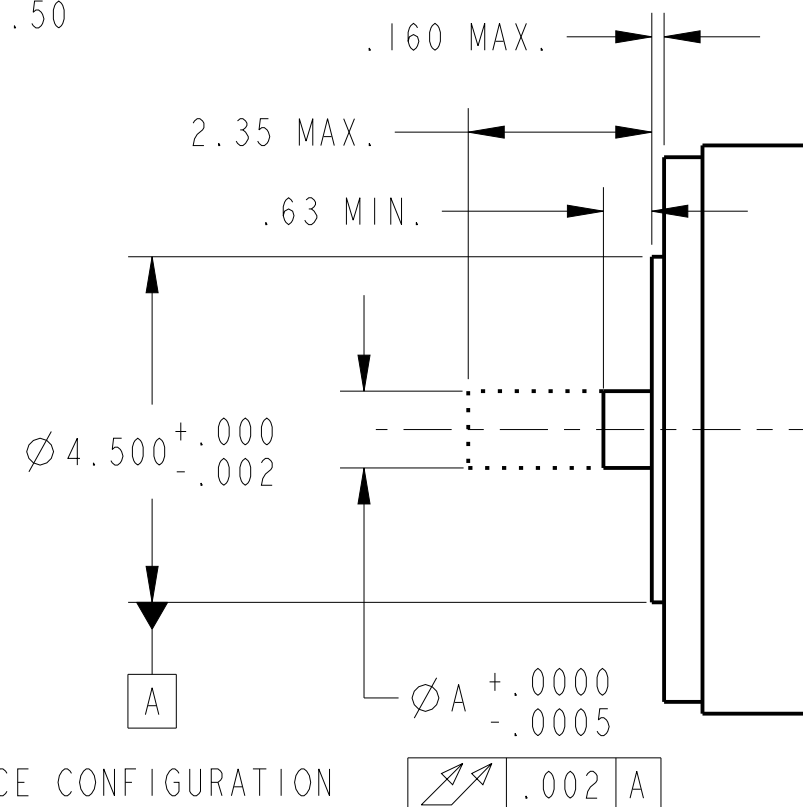

SIZE OF "A" RANGES FROM
 0.500" TO 2.875"
 ADDITIONAL SHAFT SIZES
 AVAILABLE INCLUDING METRIC

MOTOR FACE CONFIGURATION

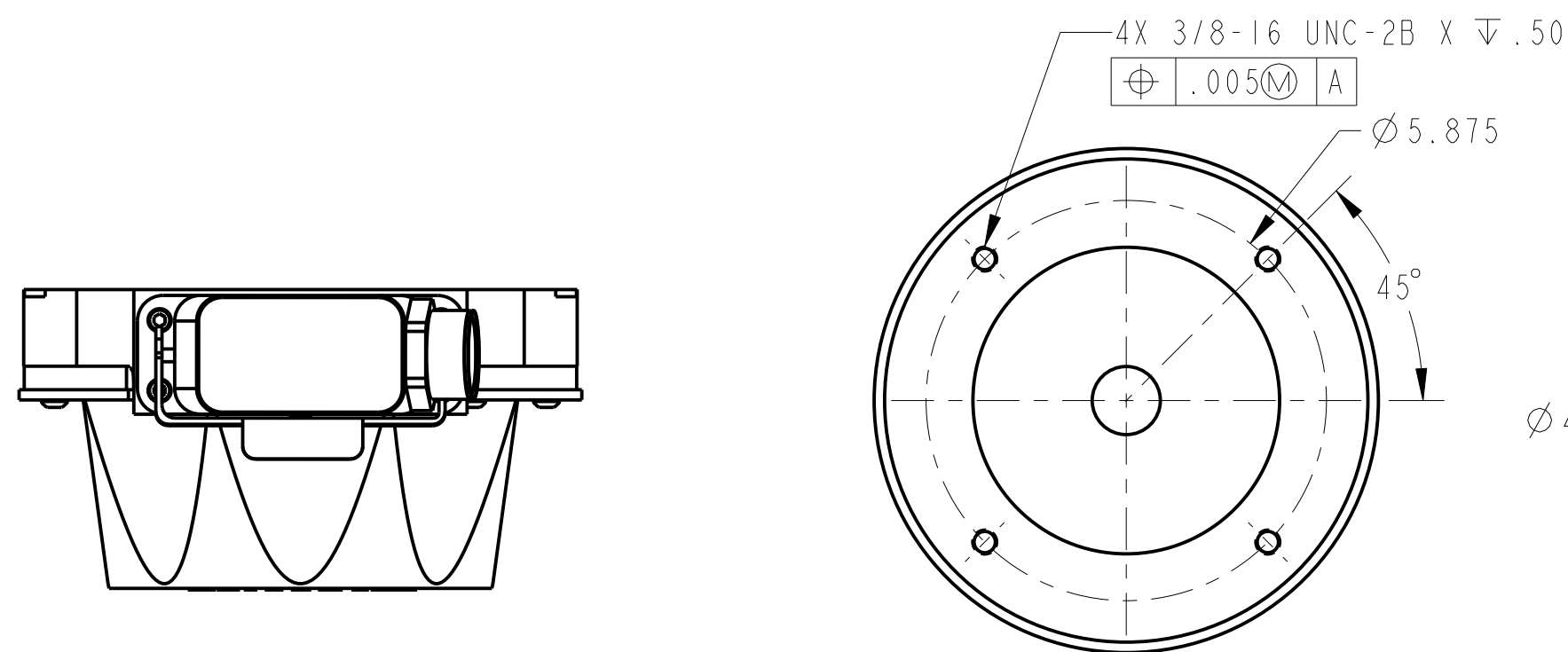
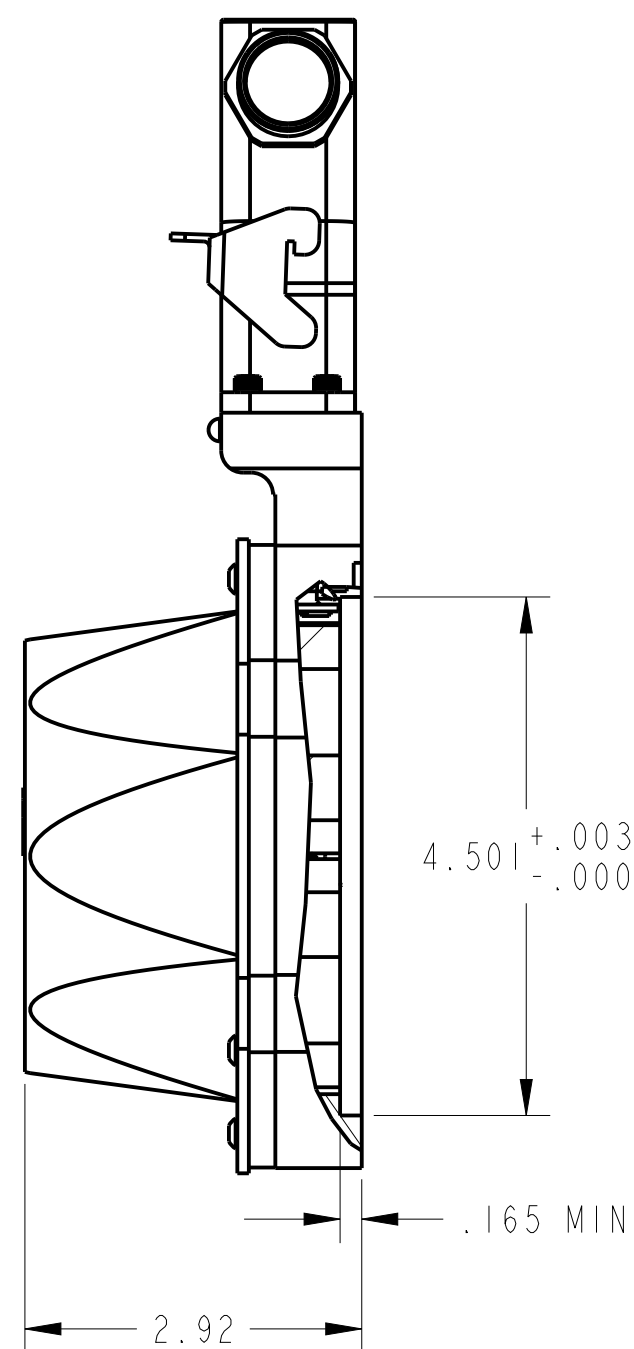
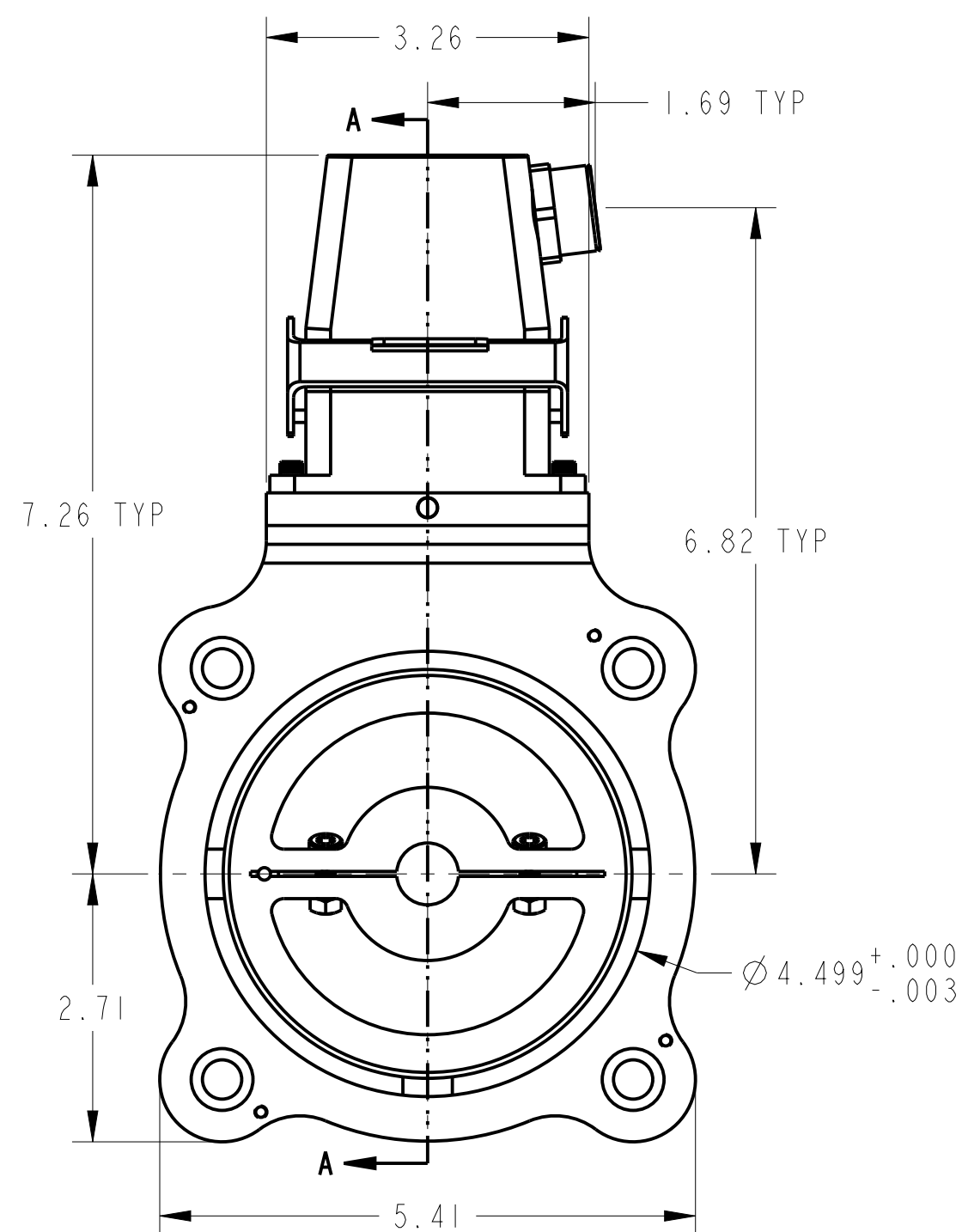

SECTION A-A

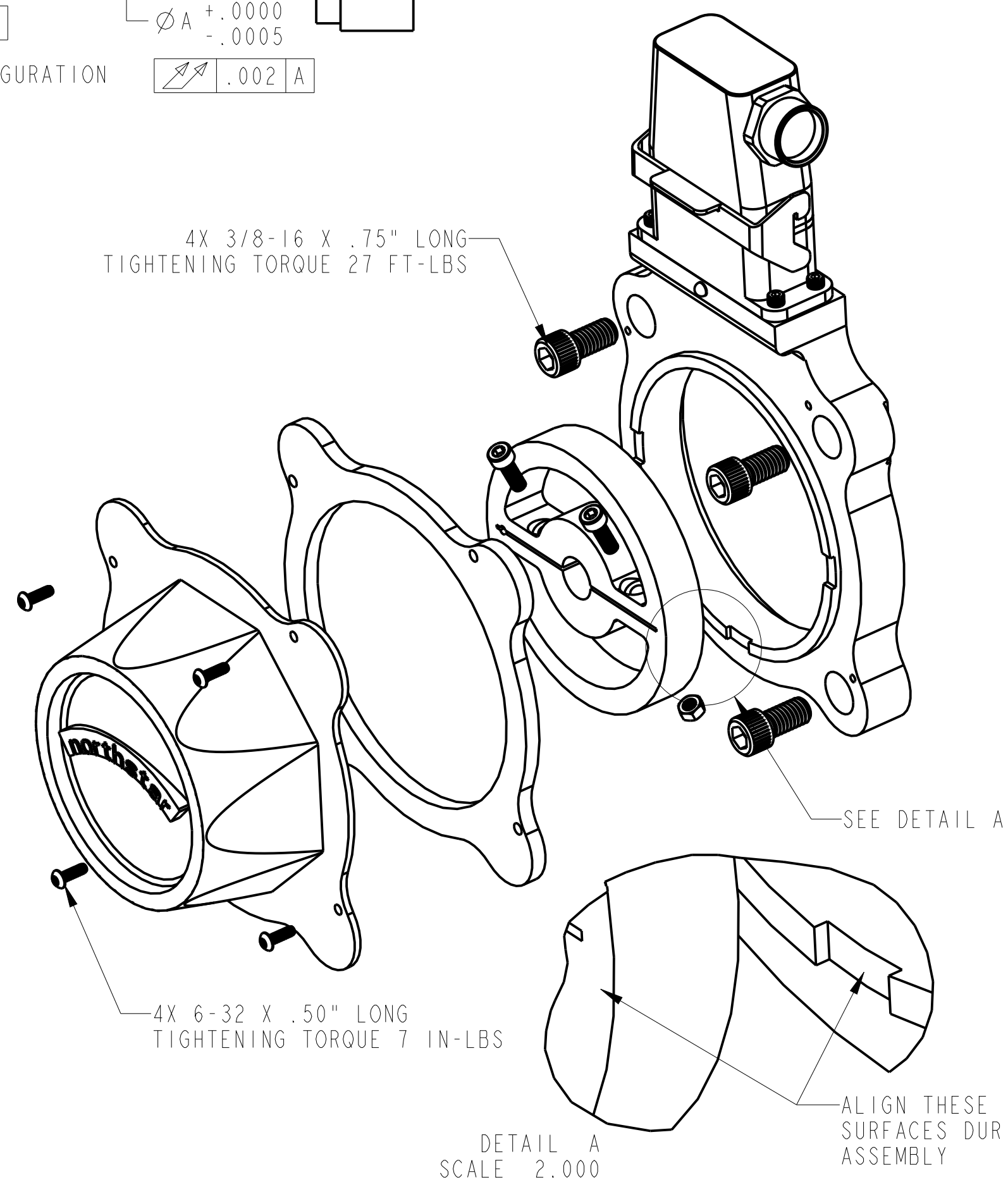

ELECTRICAL CONNECTIONS

SIGNAL	INDUSTRIAL CONNECTOR	PIGTAIL CABLE	MS CONNECTOR	TERMINAL STRIP
GND	1	BLACK	F	1
B	2	GREEN	B	5
A	3	BLUE	A	3
Z	4	VIOLET	C	7
ALARM	5	-	G	-
+Vs	6	RED	D	2
B/	7	YELLOW	J	6
A/	8	GRAY	H	4
Z/	9	ORANGE	K	8
SHLD	10	WHT/CLR	E	-

TOLERANCES UNLESS INDICATED:		UNITS: INCH	TITLE
.XXX	.XX	/	CUSTOMER DRAWING, ST56
\pm .005	\pm .01	ANGLES 1/2°	FILE NAME: 703056-0001
		FINISH: /	SCALE: /
			COMPLIANCE REQUIRED <input type="checkbox"/> UL <input type="checkbox"/> CSA <input type="checkbox"/> CE <input type="checkbox"/> TUV <input type="checkbox"/> FCC <input type="checkbox"/> VCCI <input checked="" type="checkbox"/> RoHS <input type="checkbox"/> ATEX
			PRO/E MODEL: 703056-0001
			APPLICATION: ST56
			DRAWING NUMBER
			703056-0001
			10F4
			B



© 2012 D.T.C. "C" SIZE

STANDARD HOUSING - DUAL C-FACE

REV	ECN	DATE	APPROVED

C DECODE
LATCHING INDUSTRIAL
CONNECTOR

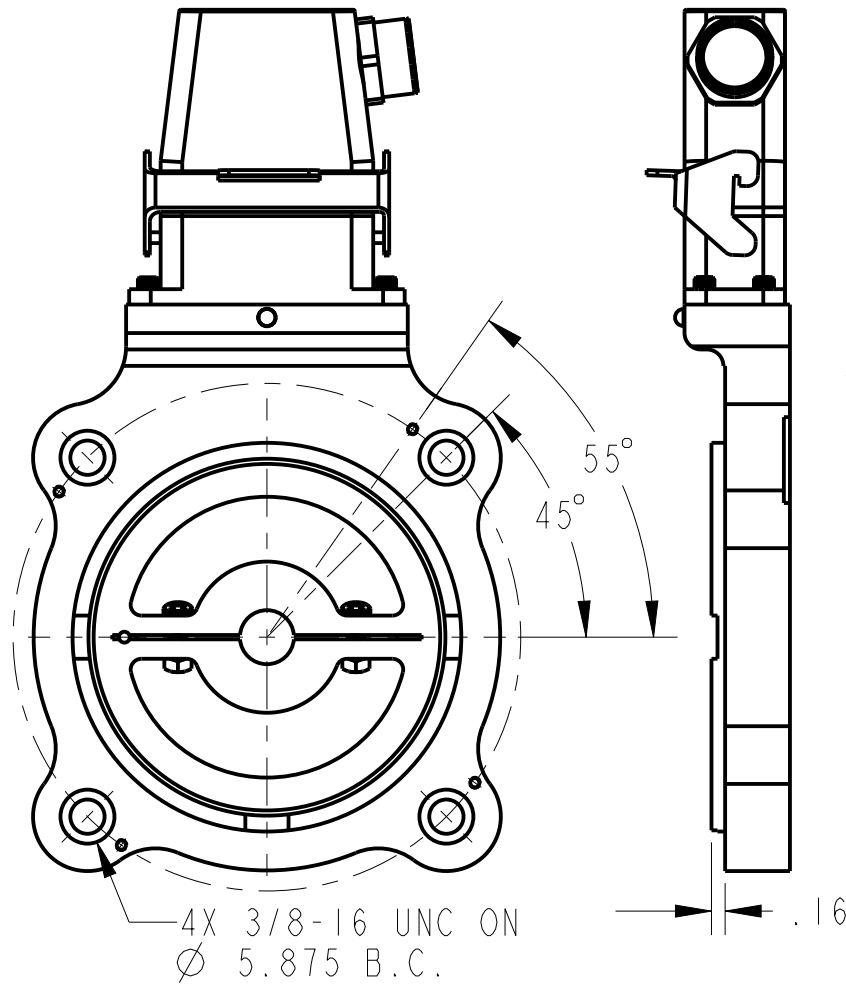

N DECODE
10 PIN MS 3112
CONNECTOR

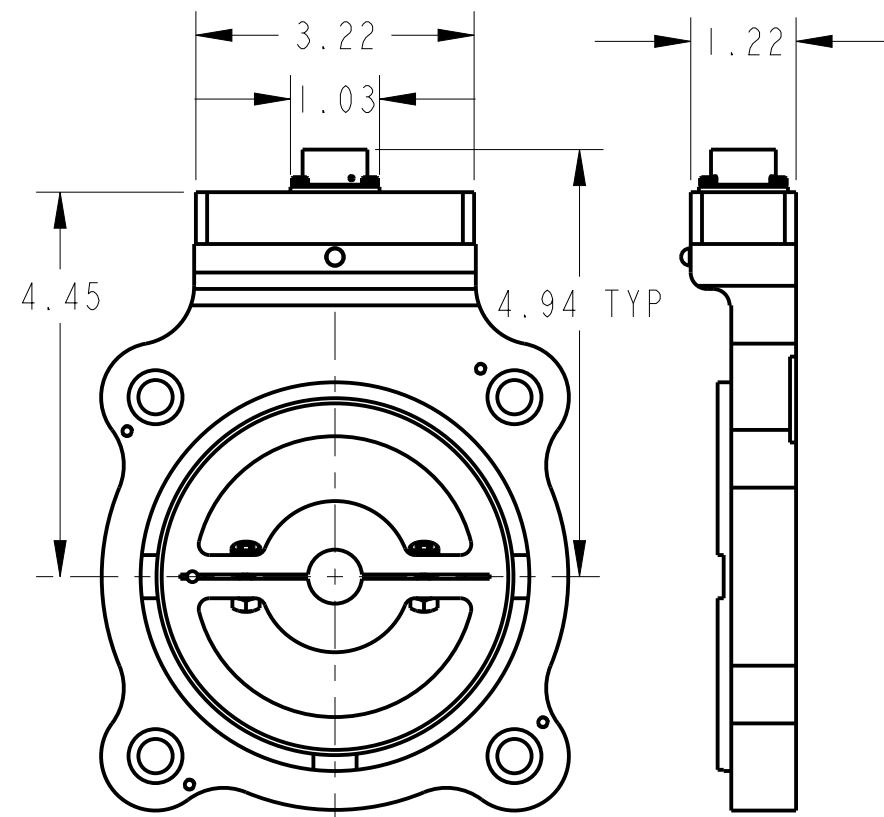

M DECODE
10 PIN MS
CONNECTOR

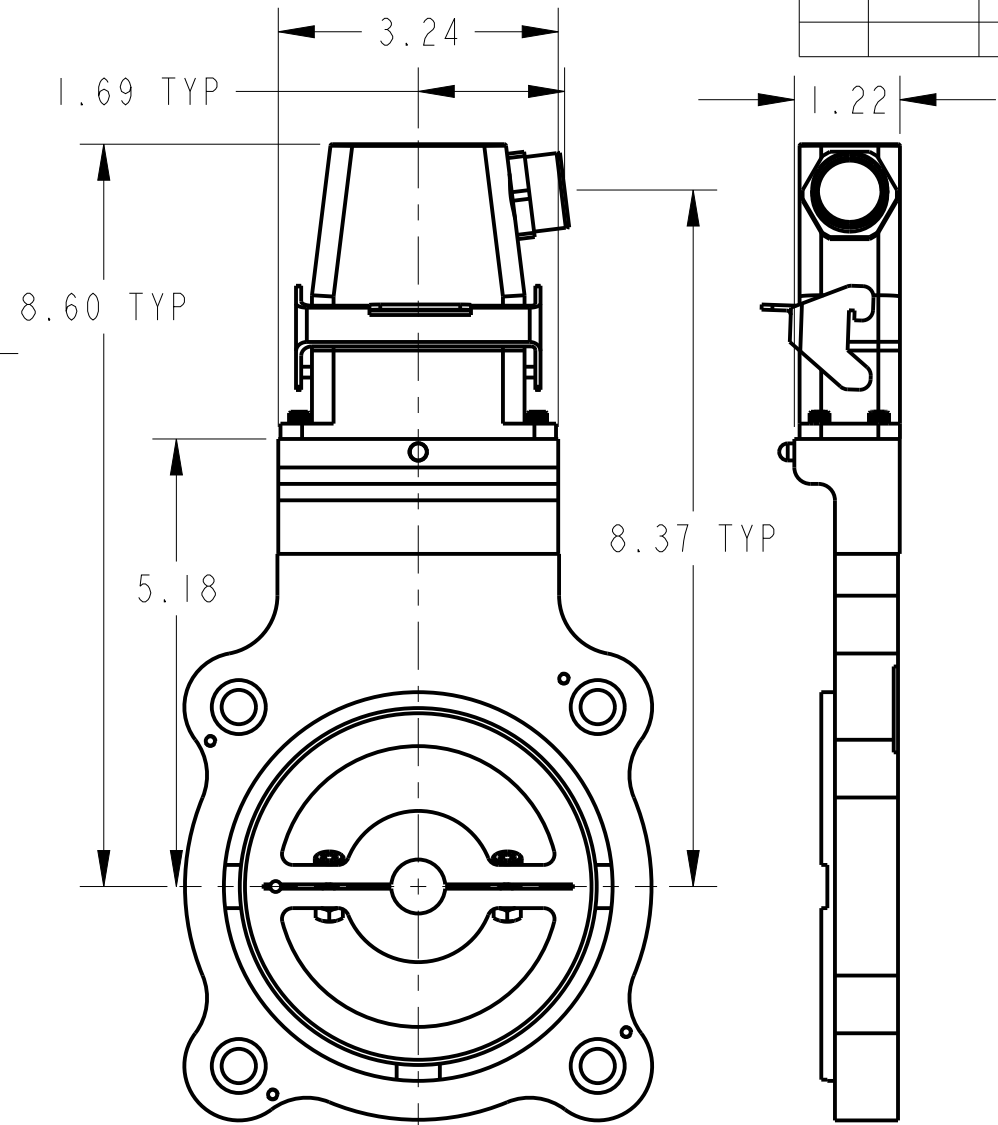
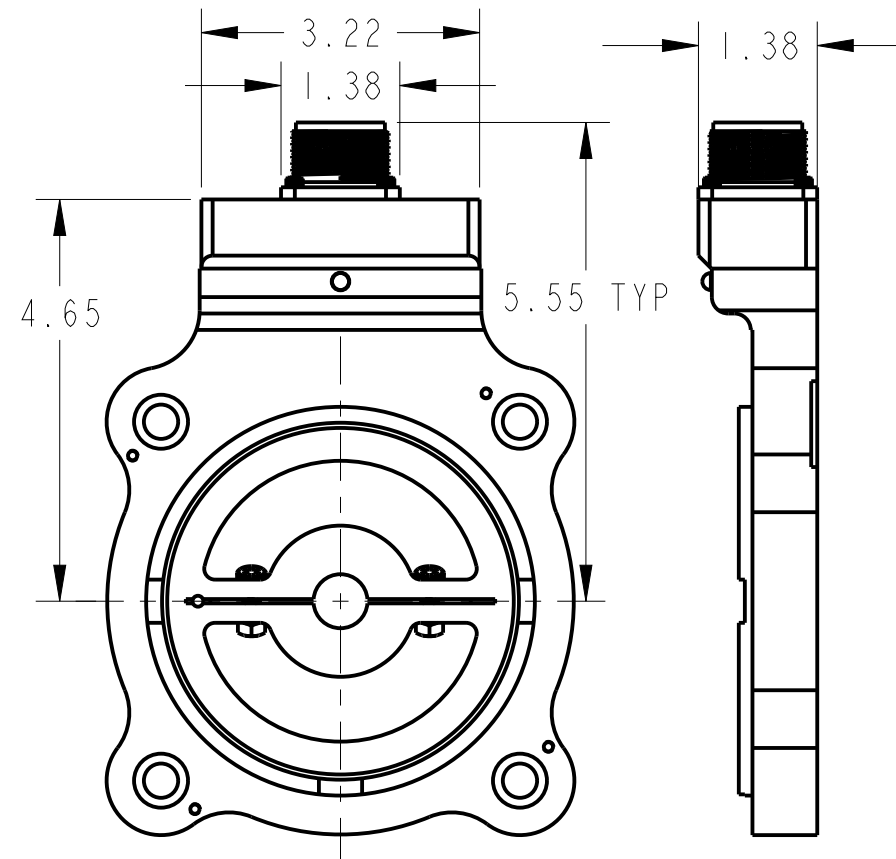

D DECODE
1" EXTENDED HEIGHT
LATCHING INDUSTRIAL
CONNECTOR

B DECODE
CONDUIT BOX

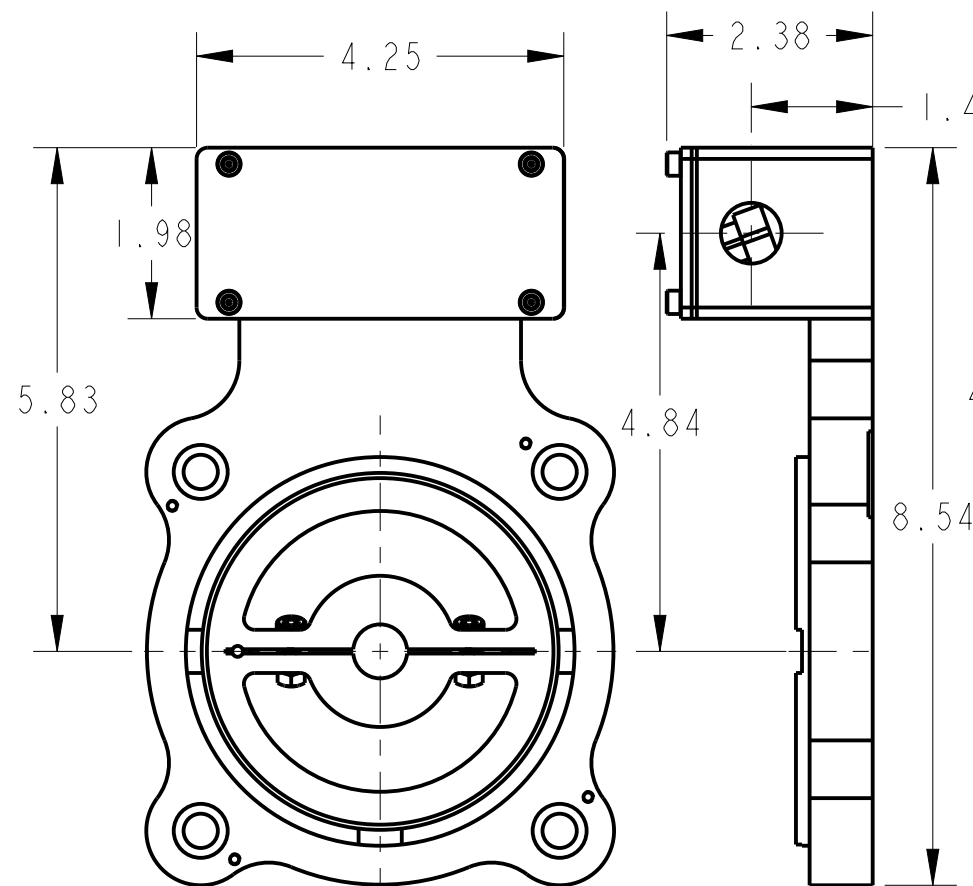

P DECODE
18" PIGTAIL CABLE

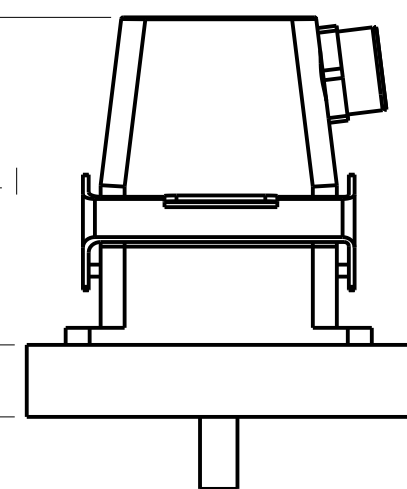
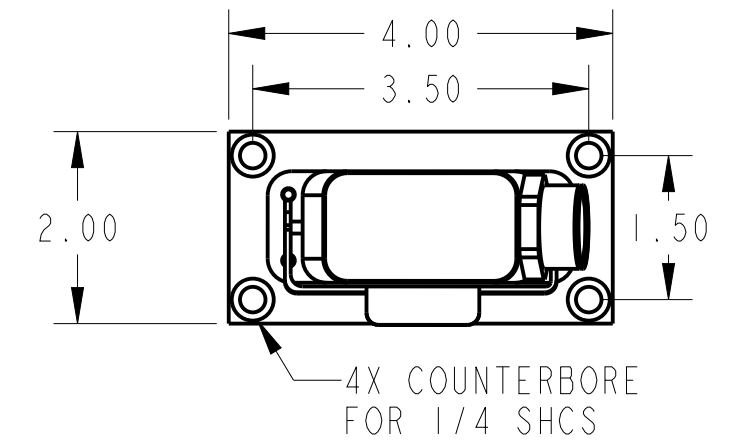
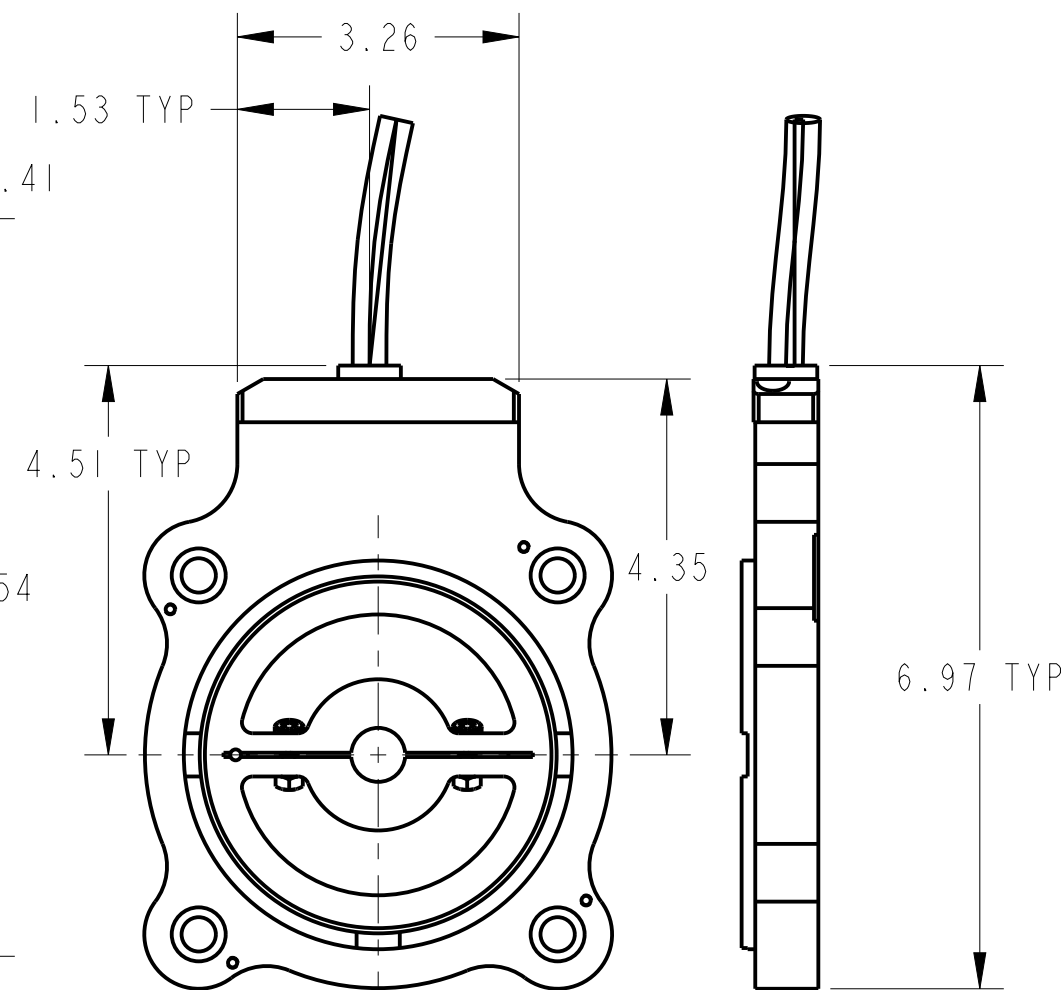

Q DECODE
LATCHING CONNECTOR
ON 18" PIGTAIL CABLE

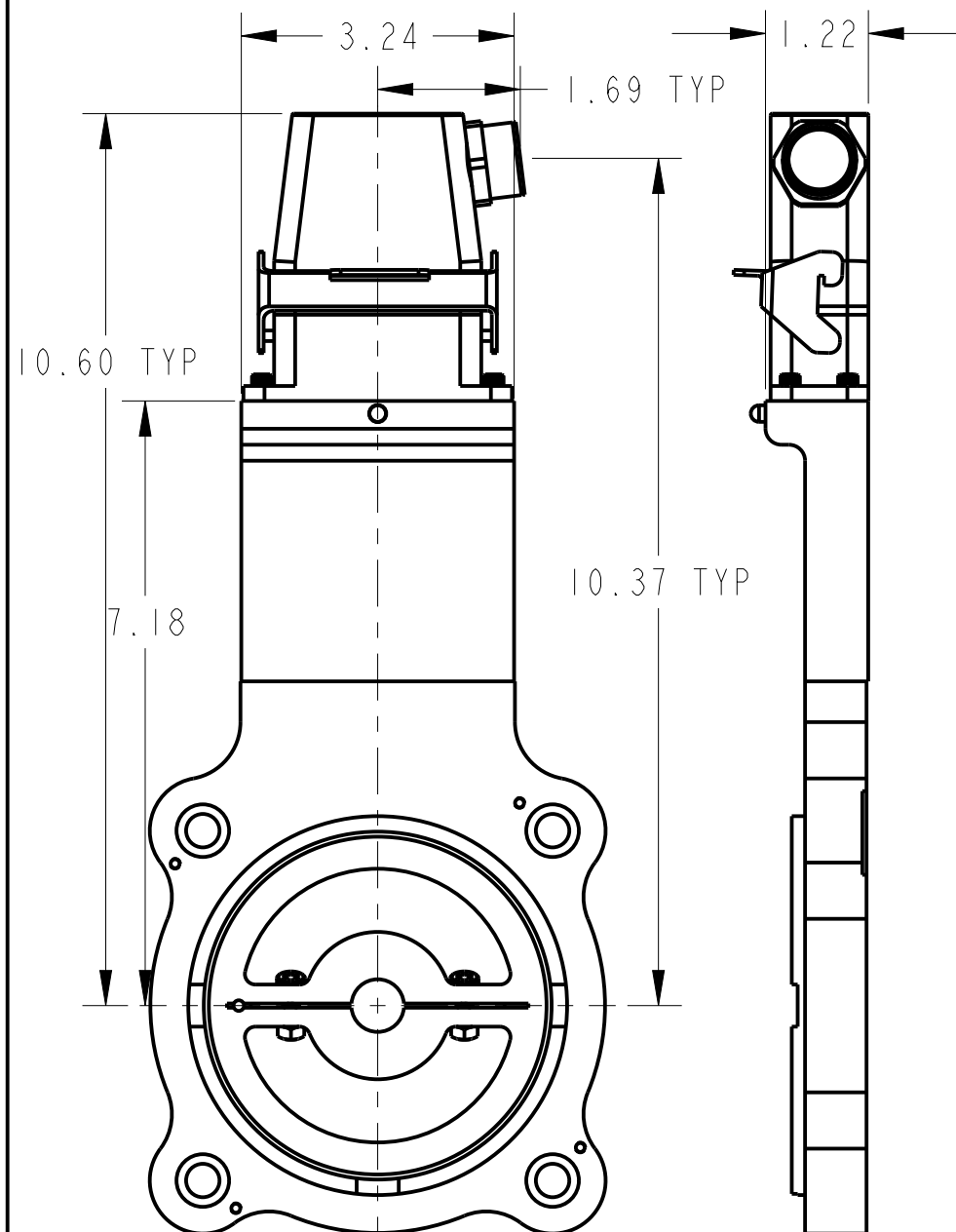

E DECODE
3" EXTENDED HEIGHT
LATCHING INDUSTRIAL
CONNECTOR

TOLERANCES UNLESS INDICATED:		UNITS: INCH	TITLE CUSTOMER DRAWING, ST56	
.XXX	.XX	ANGLES /	FILE NAME:	SCALE:
± .005	± .01	1/2° /	703056-0001	/
		FINISH:	DRAWN:	DATE:
			AJ	10/19/12
			CHECKED:	DATE:
			RELEASED:	DATE:
			AJ	10/19/12
			COMPLIANCE REQUIRED	
			<input type="checkbox"/> UL <input type="checkbox"/> CSA <input type="checkbox"/> CE <input type="checkbox"/> TUV <input type="checkbox"/> FCC <input type="checkbox"/> VCCI <input type="checkbox"/> RoHS <input type="checkbox"/> ATEX PRO/E MODEL: 703056-0001 APPLICATION: ST56 DRAWING NUMBER	
			703056-0001	20F4 A



DUAL OUTPUT HOUSING - DUAL C-FACE

REV	ECN	DATE	APPROVED

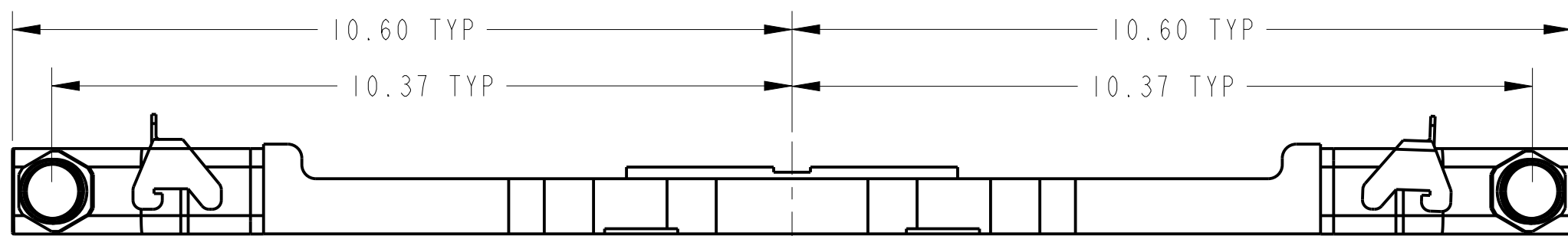
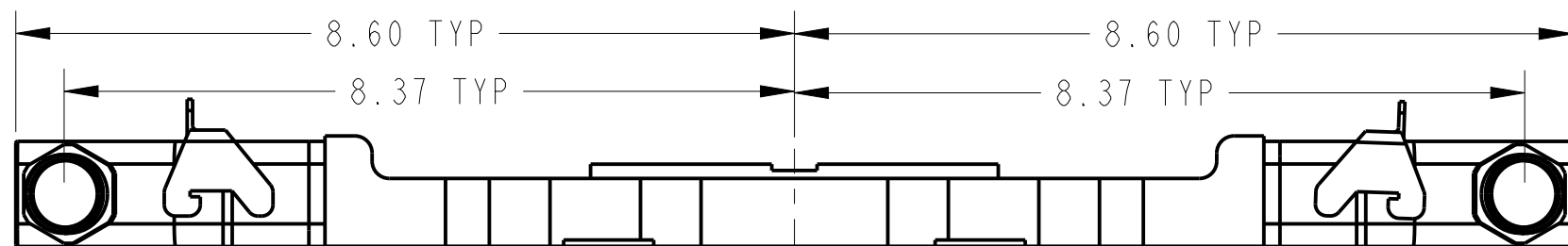
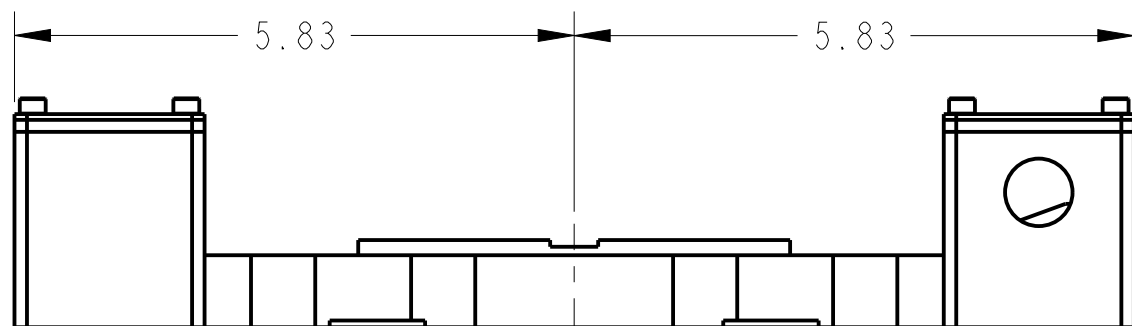
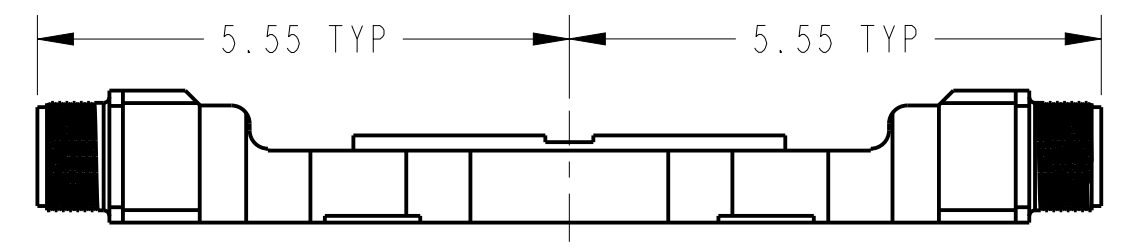
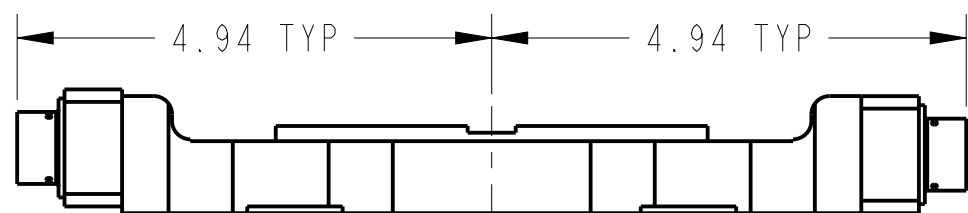
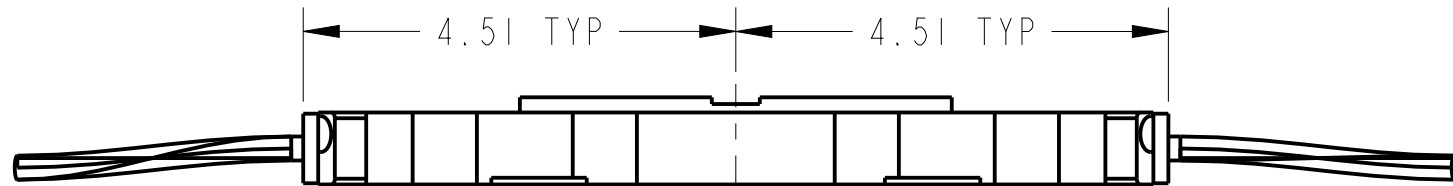
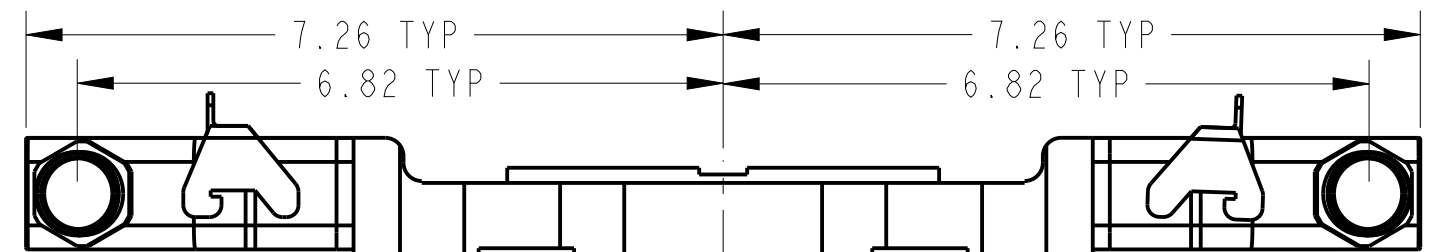
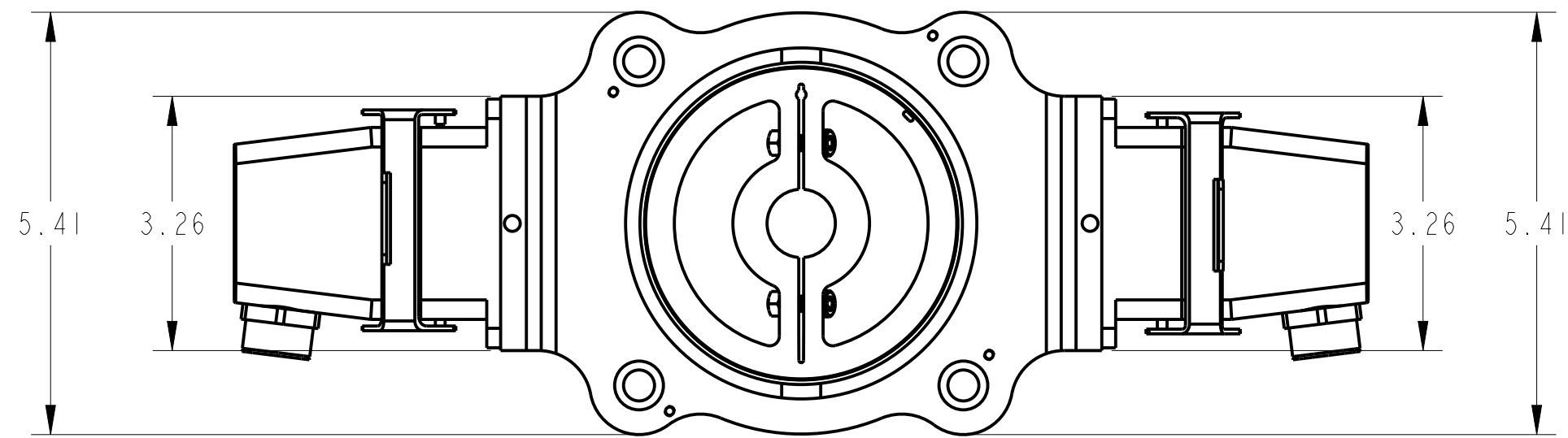

C DECODE
LATCHING CONNECTOR

P DECODE
PIGTAIL CABLE

N DECODE
MS 3112 CONNECTOR

M DECODE
MS CONNECTOR

B DECODE
CONDUIT BOX

D DECODE
1" RISER
LATCHING CONNECTOR

E DECODE
3" RISER
LATCHING CONNECTOR

CLAMP WHEEL

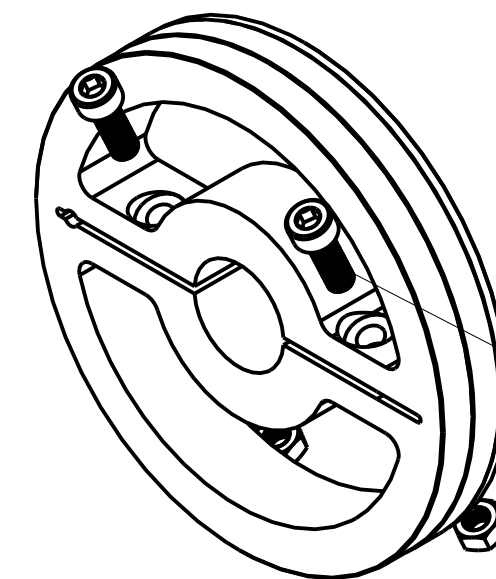

SIZE OF BORE RANGES FROM
0.500" TO 1.500"

2X M5 X 0.8 SCREWS
TIGHTENING TORQUE 23 IN-LBS (2.6 N-M)

COLLET WHEEL

SIZE OF BORE RANGES FROM
1.625" TO 2.875"

4X M4 X 0.7 SCREWS
TIGHTENING TORQUE 21 IN-LBS (2.3 N-M)

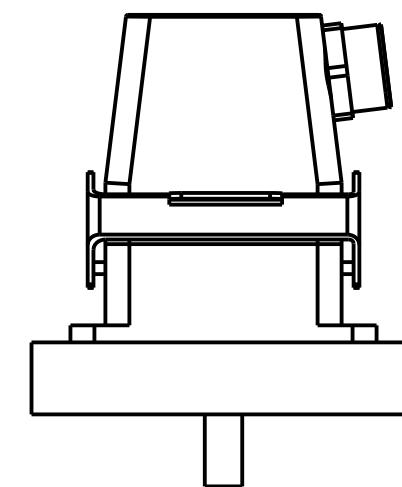
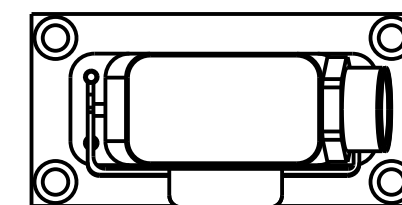
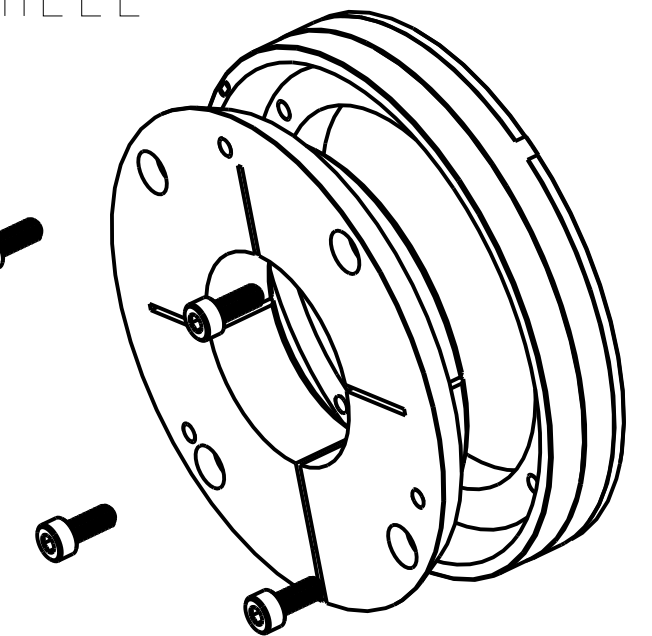

Q DECODE
LATCHING CONNECTOR
ON 18" PIGTAIL CABLE

TOLERANCES UNLESS INDICATED:		UNITS: INCH	TITLE CUSTOMER DRAWING, ST56	
.XXX	.XX	MATERIAL:	FILE NAME:	SCALE:
± .005	± .01	FINISH:	703056-0001	/
ANGLES	1/2°	© 2012 D.T.C.	DRAWN:	DATE:
		"C" SIZE	AJ	10/19/12
COMPLIANCE REQUIRED		CHECKED:		DATE:
<input type="checkbox"/> UL	<input type="checkbox"/> CSA	<input type="checkbox"/> CE	<input type="checkbox"/> TUV	APPLICATION: ST56
<input type="checkbox"/> FCC	<input type="checkbox"/> VCCI	<input checked="" type="checkbox"/> RoHS	<input type="checkbox"/> ATEX	DRAWING NUMBER
PRO/E MODEL: 703056-0001		RELEASED:		DATE:
703056-0001 30F4		AJ		10/19/12
				REV
				A

COVER OPTIONS CODE 7

REV	ECN	DATE	APPROVED

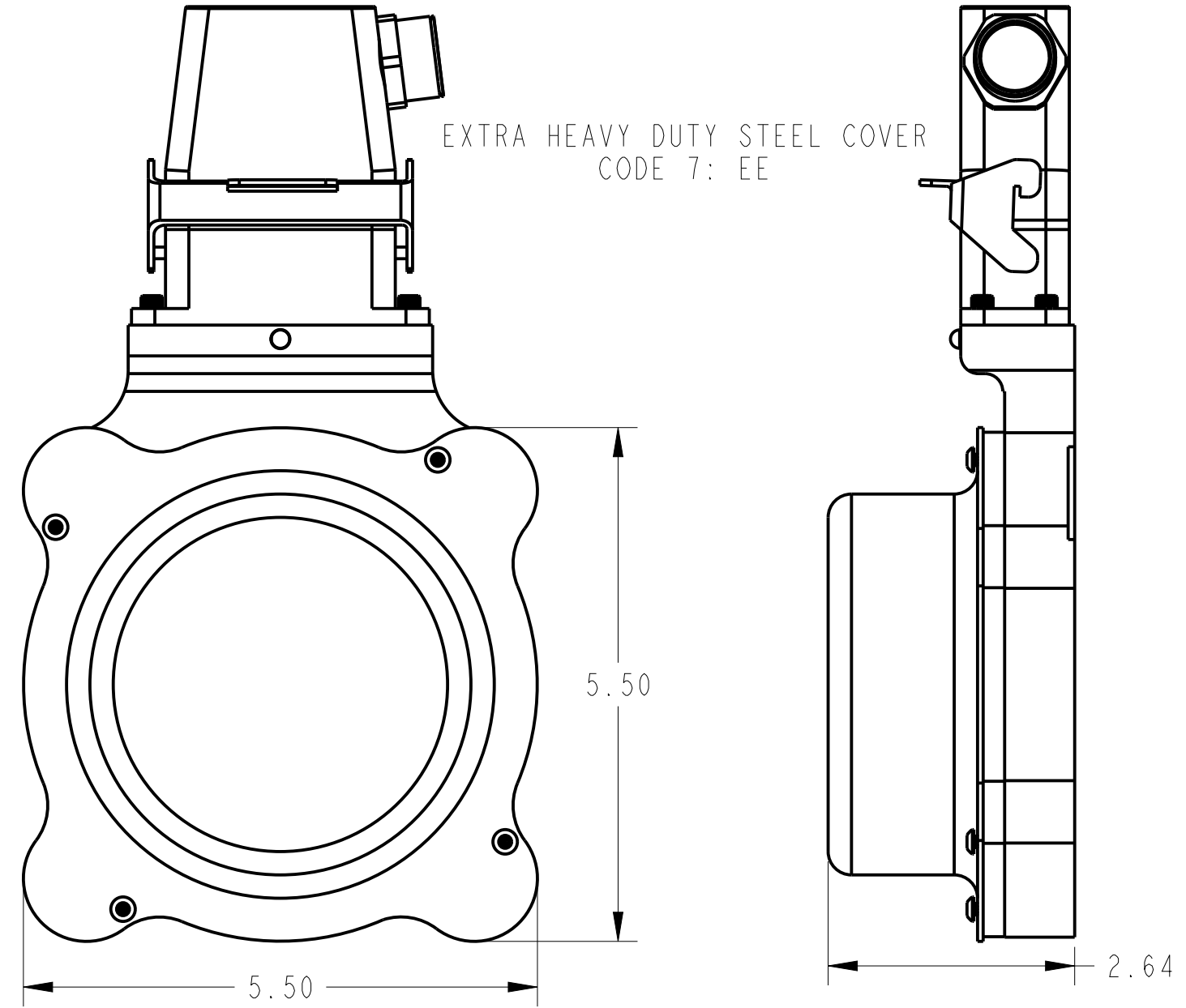
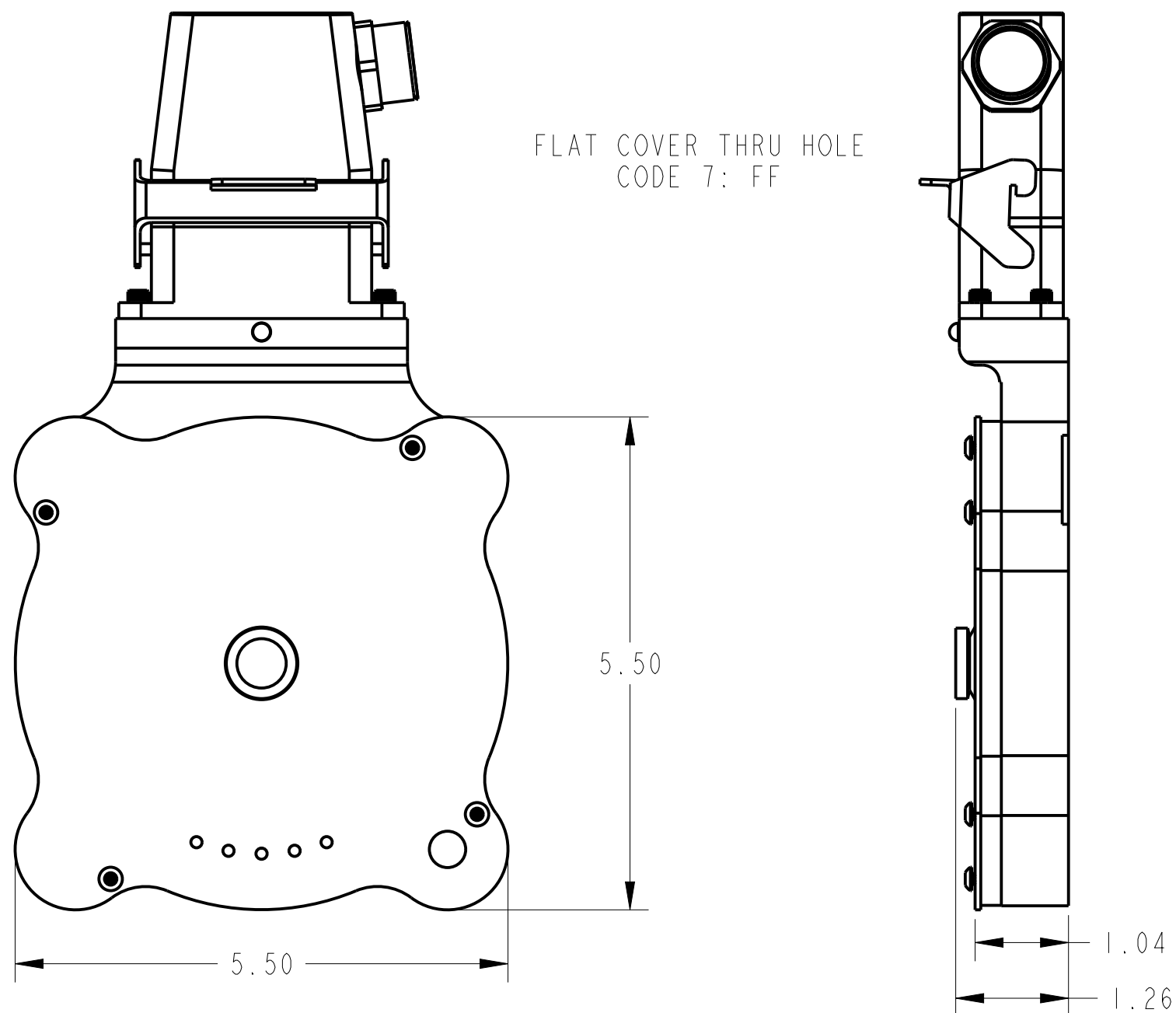
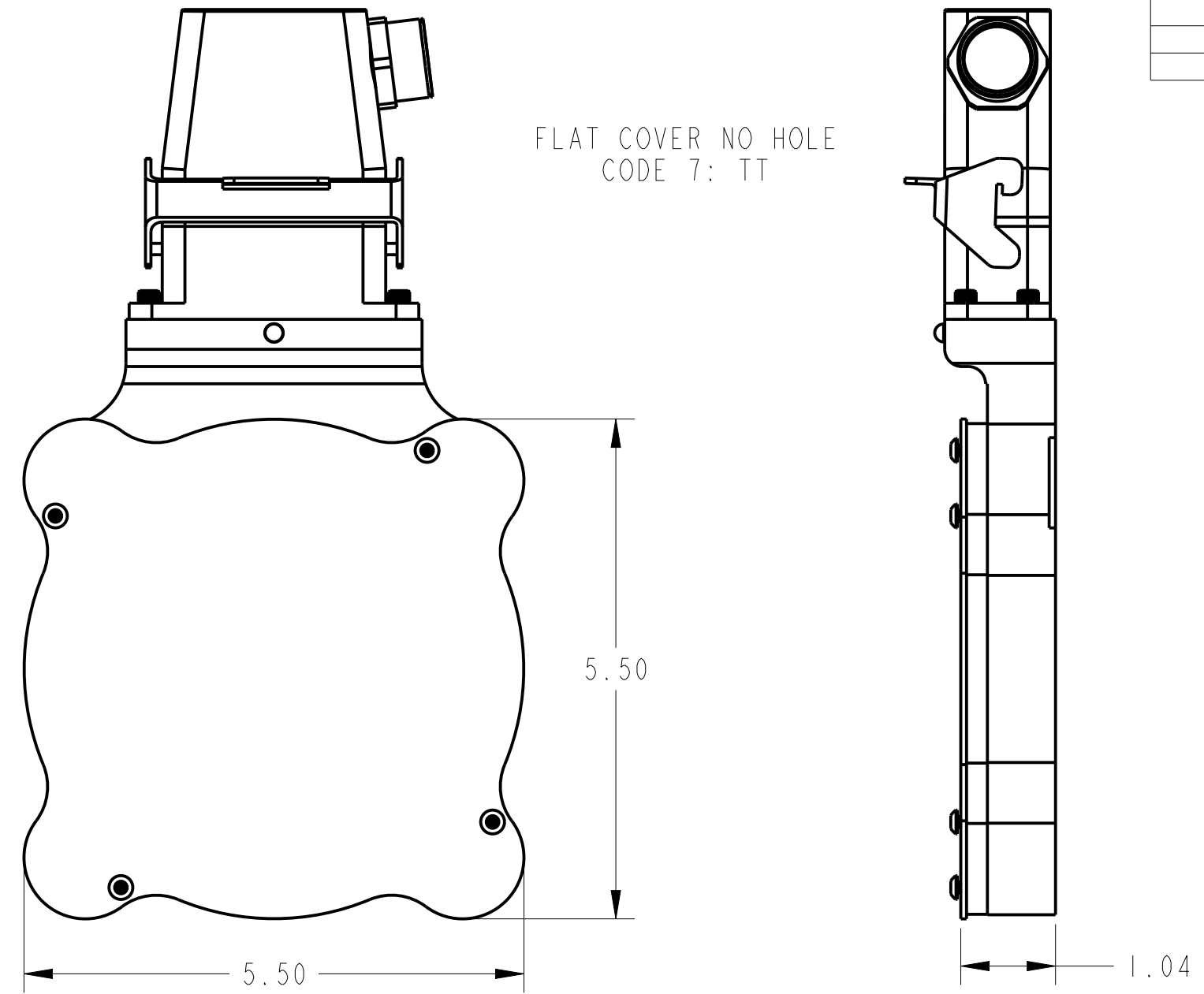
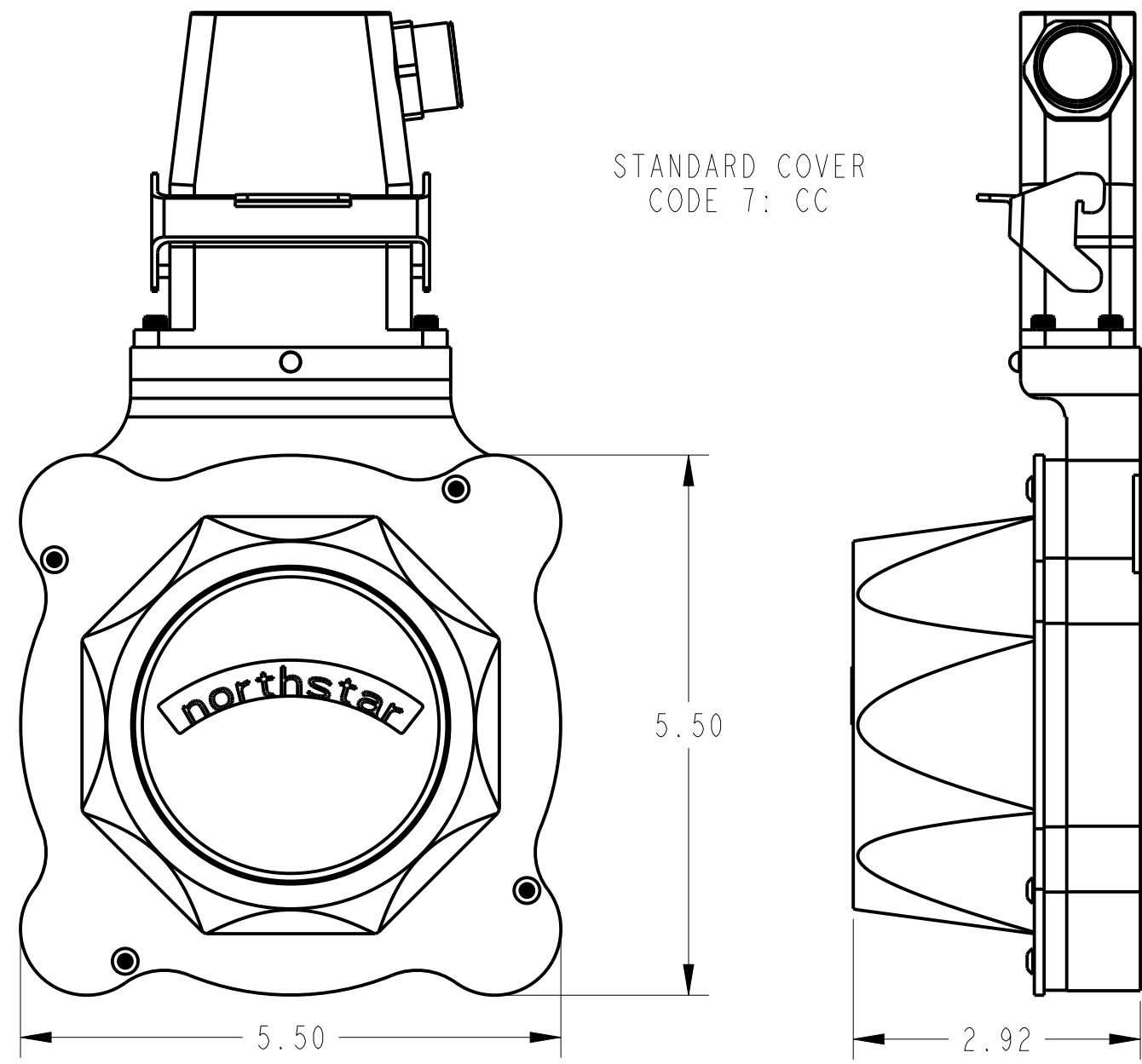

TOLERANCES UNLESS INDICATED:		UNITS: INCH	TITLE CUSTOMER DRAWING, ST56	
.XXX	.XX	ANGLES	FILE NAME:	SCALE:
±	±	±	703056-0001	/
.005	.01	1/2°	DRAWN:	DATE:
			AJ	10/19/12
FINISH:			CHECKED:	DATE:
© 2012 D.T.C.		"C" SIZE	RELEASED:	DATE:
DYNAPAR™			AJ	10/19/12
			DRAWING NUMBER	COMPLIANCE REQUIRED
			703056-0001	<input type="checkbox"/> UL <input type="checkbox"/> CSA <input type="checkbox"/> CE <input type="checkbox"/> TUV
			40F4	<input type="checkbox"/> FCC <input type="checkbox"/> VCCI <input checked="" type="checkbox"/> RoHS <input type="checkbox"/> ATEX
			A	PRO/E MODEL: 703056-0001
				APPLICATION: ST56
				DRAWING NUMBER
				703056-0001
				REV
				40F4
				A